



# Markel<sup>®</sup> Products Company



## 2023 MECHANICAL PRODUCTS CATALOG

Ventilation - Fans - Industrial Lighting

 [www.linkedin.com/company/tpi-corporation/](https://www.linkedin.com/company/tpi-corporation/)

 [www.facebook.com/tpicorporation](https://www.facebook.com/tpicorporation)

 [www.youtube.com/user/tpicorporation](https://www.youtube.com/user/tpicorporation)

 [www.instagram.com/tpi\\_corporation/](https://www.instagram.com/tpi_corporation/)

TEL: 1-800-682-3398 | 1-423-477-4131 | FAX: 1-423-477-0064 | [www.tpicorp.com](http://www.tpicorp.com)

LIGHTS

FANS

# Table Of Contents & Limited Warranty

CATEGORY	PAGE
<b>INDUSTRIAL CIRCULATORS</b>	
24" & 30" Assembled Maximum Duty	2
20" to 36" Assembled Circulator Heads & Mounts	3
20" 24" & 30" Unassembled Circulators	4
20" 24" & 30" Specialty Circulator Heads	5
Components - Motor Comparisons	6
Air Circulators - Motor Comparisons	7
<b>COMMERCIAL CIRCULATORS</b>	
20", 24" & 30" Commercial Non-Osc. Circulators	8
20", 24" & 30" Commercial Oscillating Circulators	8
<b>COMMERCIAL BLOWERS</b>	
36" 42" & 48" Belt Drive Portable	9
24" 30" & 36" Direct Drive Portable	9
<b>INDUSTRIAL BLOWERS</b>	
30" 36" & 42" Direct Drive Portable	10
48" Direct Drive Portable	10
36" 42" & 48" Belt Drive Portable	11
30" 36" & 42" Direct Drive Suspension	12
36" 42" & 48" Belt Drive Suspension	12
24" & 30" Mini	13
Heavy Duty Square Belt Drive Portable	13
High Velocity	14-15
Heavy Duty Direct Drive	16
Heavy Duty Permanent Mount Direct Drive	17
<b>WORKSTATION FANS</b>	
Industrial Floor	18
Industrial Mounted	19
Outdoor Rated Yoke Mount	19
Commercial Floor	20
Oscillating Office	20
Wall Mounted With Pivoting Arm	21
Low Velocity "Special Application"	21

CATEGORY	PAGE
<b>CEILING FANS</b>	
Industrial Ceiling Fans	22
<b>EXHAUST FANS &amp; GUARDS</b>	
Shutter Mounted Direct Drive	23
Guard Mounted Direct Drive	24
Venturi Mounted Direct Drive	25
Commercial Belt Drive - (Fans & Shutters)	26
Industrial Direct Drive	27
Industrial Belt Drive	28
Heavy Duty Direct Drive	29
Heavy Duty Belt Drive	30
Cabinet Exhaust Fans With Shutters	31
Accessories / Heavy Duty Shutters	32
Cabinet Accessories / Guards	33
Cabinet Exhaust Fan Package Options	34
Weather Hood	34
<b>ROOF VENTILATORS</b>	
Insulated Roof Curbs	35
Belt Drive Hooded Roof Ventilator	36
Direct Drive Roof Ventilator	37
Belt Drive Roof Ventilator	38
<b>TUBEAXIAL DUCT FAN</b>	
Direct Drive & Guards	39
Belt Drive	40
<b>ATTIC FANS</b>	
Roof Domes, Gable Fans, Attic Fans	41
<b>INDUSTRIAL LIGHT PRODUCTS</b>	
Loading Dock Lights	42
Modular Loading Dock Lights	43
Machine Tool Lights	44
Commercial Utility Lights	44
<b>PRODUCT INDEX</b>	

TPI Corporation provides a limited warranty of materials and workmanship for a period of (i) ten (10) years for elements in 2900 Series baseboard heaters, (ii) two (2) years for Thermostats and Controls, (iii) five (5) years on HD and HDH series fans, (iv) three (3) years on UHP and IHP series fans, (v) and twelve (12) months for all other products, with the warranty period commencing on the original date of purchase. The TPI warranty is limited to materials manufactured and work performed by TPI Corporation, and does not include damage or failure caused by acts of God, abuse, misuse, connected to or placed on other than rated voltage, abnormal usage, faulty installation, failure to follow suggested maintenance procedures enclosed with the product, improper maintenance or any repairs other than those provided by an authorized TPI Corporation service center. For the name of your nearest authorized TPI Corporation service center, please write to TPI Corporation, P.O. Box 4973, Johnson City, Tennessee, 37602 or call 1-800-682-3398.

During the warranty period, TPI Corporation will, at its sole option, repair or replace any defective parts or products returned, freight prepaid, to the TPI Corporation factory or such other location as TPI Corporation may designate. No parts or products will be accepted for repair or replacement without prior authorization from TPI Corporation and a return merchandise authority (RMA) number issued by TPI Corporation. Returned products must be packaged carefully and TPI Corporation shall not be responsible for damage in transit. When returning parts, the owner must provide the model number of the product and nature of difficulty being experienced.

This warranty does not obligate TPI Corporation to bear the cost of labor in replacing any assembly, unit or component part thereof, nor does TPI Corporation assume any liability for secondary charges, expenses for installing or removal, freight or damages. There will be charges rendered for product repairs made after the warranty period has expired. Proof of purchase, including date, must accompany request for in-warranty service. This warranty gives you specific legal rights and you may have other rights, which may vary, from state to state.

Except for the limited warranty provided in the foregoing paragraph, all parts and products sold by TPI Corporation are sold 'as is', 'where is', and without any other warranty of any kind or nature, whether express, implied, or statutory and including, without limitation, any implied warranty of specific performance or merchantability.

Under no circumstances, even with respect to claims covered by the foregoing warranty, will TPI Corporation be responsible for any incidental, consequential, special, or punitive damages of any kind or nature arising from or related to the parts or products sold by TPI Corporation.

In any event, TPI Corporation's maximum liability shall not in any case exceed the purchase price for the part or product claimed to be defective.

You hereby expressly agree to waive any and all rights to a trial by jury with respect to any product manufactured or supplied by TPI Corporation.

Ventilation Products Warranty Coverage	
Series HD or HDH fans	5 Years
Series UHP or IHP fans	3 Years
All other ventilation products	1 Year

## RETURN POLICY:

Requests for returns of non-defective standard stock units may incur testing and repackaging charges if units are not in like new condition. Requests for returns of build to order items are subject to cancellation charges prior to shipment and up to a 100% restocking charge after shipment. This also applies to any standard model with factory installed control options or other custom features. Changes made to custom products during production may incur labor charges. Please consult factory for details on any return or change order

## TPI COMMERCIAL CIRCULATORS STATEMENT:

TPI Commercial circulators have been developed to equal the imported circulators that are sold by big-box retail stores and some catalogers. Because these circulators do not have totally enclosed motors, they should be used in clean, dry commercial applications - such as schools, shops, offices, and warehouses.  
Note: Prices subject to change without notice.

# TPI Industrial Assembled Maximum Duty Circulators

## Features

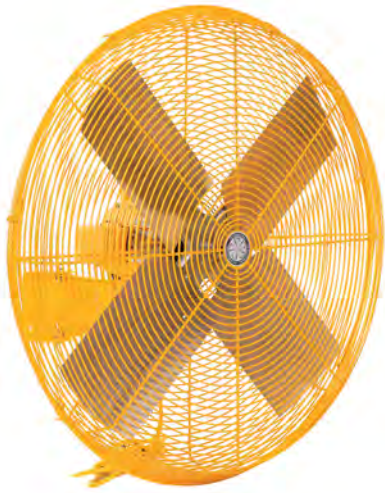

**HDH Series**

- Steel construction with safety yellow textured epoxy powder coated finish
- Direct drive, Totally Enclosed Air-Over (TEAO) motor generating up to 8,000-CFM's
- Aluminum 4-paddle blade system with steel hub and cast aluminum spider connections
- HDH-Series contains a pull-chain switch and 12' long SJT-Type cord with grounded plug
- HDH-JR Series contains a 12' long SJT-Type cord with grounded plug and 18" long drop-down cord assembled with an electrical (off, on low/high) switch enclosure
- Fully-Assembled Non-Oscillating fan heads in 24" or 30" diameter sizes
- 5-year motor warranty
- Made in the U.S.A. with domestic and foreign components

## Motor Specifications

- 2-speed / 1-phase, 120V
- Permanent split capacitor
- Frame size: 48
- 1/2 HP
- Ball bearing
- Totally enclosed, permanently lubed
- 1/2" Shaft

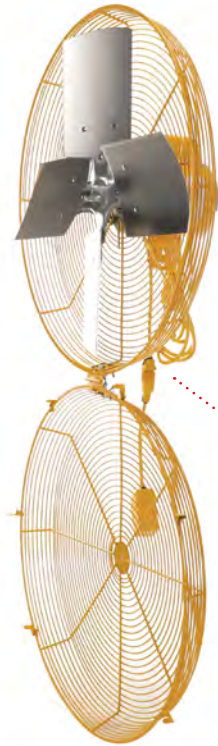

Hinged Guard



**HDH-JR Series**



Drop-Down Switch



Wall Mount  
see pg. 6



DIMENSIONS	
24"	27" Diameter x 14.5" Depth
30"	33.5" Diameter x 14.5" Depth



Pedestal Mount, see pg. 6

**WARNING:** This product can expose you to chemicals including nickel which is known to the State of California to cause cancer, and chromium, which is known to the State of California to cause birth defects and/or reproductive harm. For more information go to [www.P65Warnings.ca.gov](http://www.P65Warnings.ca.gov).

## Standard Models

ASSEMBLED FAN HEAD		BLADE SIZE	SWITCH TYPE	HP	CFM* / RPM		VELOCITY PROFILE	AMPS	WT. (LBS)
MFG CATALOG NUMBER	MFG MODEL NUMBER				CFM / Area Sq Ft				
08744402	HDH 24-JR	24"	Drop Down	1/2	5600 / 1100	4900 / 800	7500 / 260	3.5	44
08744602	HDH 30-JR	30"			6800 / 1100	6000 / 800	8000 / 270	4	48
07960702	HDH 24	24"	Pull Chain		5600 / 1100	4900 / 800	7500 / 260	3.5	44
07960802	HDH 30	30"			6800 / 1100	6000 / 800	8000 / 270	4	48

\*Measured 2 feet from face of fan

TPI offers six factory assembled and tested fan mounts that can be used with any of the non-oscillating TPI Industrial heads.

# TPI Industrial Assembled Circulator Heads and Mounts

## Features

- Steel construction with silver/gray powder coated; steel motor housing painted black
- Direct drive, totally enclosed air-over (TEAO) motor generating up to 12,000-CFM's
- Aluminum 3-paddle blade system with steel hub and cast aluminum spider connections
- All models contain a pull-chain switch and 12' long SJT-Type cord with grounded plug
- All models, except **HDH-36**, contain self-locking retaining clips to secure front/rear grills and meet OSHA safety requirements
- **HDH-36 model is preassembled and ships altogether in one carton; operates at single speed, contains interlocking front/rear grills and includes mounting bracket**
- HDH-GJR Series contains a 12' long SJT-Type cord with grounded plug and 18" long drop down cord assembled with an electrical (off, on low/high) switch enclosure
- Fully-assembled ready for plug-&-play operation offered in non-oscillating (stationary) and oscillating fan heads in 20", 24" or 30" diameter sizes; mounts sold separately
- Oscillating models rotates in a 90° arc or can be locked in a fixed position
- Metal gears in the oscillating model allow the fan to operate at a maximum 30° downward tilt
- Motor warranty ranges from 1, 3 and 5-years
- Made in the U.S.A. with domestic and foreign components

## Motor Specifications

- 3-Speed
- 1 Phase, 120V
- Ball bearing
- Frame size: 48
- Totally enclosed
- Permanent split capacitor
- Permanently lubricated
- ½" Shaft

DIMENSIONS	
20"	22" Diameter x 14.5" Depth
24"	27" Diameter x 14.5" Depth
30"	33.5" Diameter x 14.5" Depth



**WARNING:** This product can expose you to chemicals including nickel which is known to the State of California to cause cancer, and chromium, which is known to the State of California to cause birth defects and/or reproductive harm. For more information go to [www.P65Warnings.ca.gov](http://www.P65Warnings.ca.gov).



**ACM-IHP-HDH Series**



**HDH-GJR Series**  
Drop-Down Plug and Hinged Guard



**ACH-O Series**  
Oscillating Motor

## Standard Models

H.P.	BLADE SIZE	MFG MODEL NUMBER	MFG CATALOG NUMBER	FAN HEAD TYPE	CFM*	VELOCITY PROFILE	RPM	AMPS	WT. (LBS)
						CFM / Area Sq Ft			
1 Year Warranty									
Industrial 1/4	20"	ACH 20	08684702	STATIONARY	3000 / 2600	5000 / 200	1100 / 900	2.4	39
	24"	ACH 24	07961602		3800 / 3400	6000 / 240	1100 / 800	2.5	40
	30"	ACH 30	07961702		4300 / 3800	7200 / 250	1100 / 800	2.7	44
3 Year Warranty									
High Performance 1/3	24"	IHP 24-H	07989802	STATIONARY	4300 / 3900	6000 / 240	1100 / 800	2.8	40
	30"	IHP 30-H	07989902		5400 / 4700	7200 / 250	1100 / 800	3	44
	36"	HDH 36	08197802		6970	12000 / 325	1100	5.2	90
5 Year Warranty									
Heavy Duty 1/2	24"	HDH 24-G	08539202	STATIONARY	5600 / 4900	7500 / 260	1100 / 800	3.5	44
	30"	HDH 30-G	08528602		6800 / 6000	8000 / 270	1100 / 800	4	48
	24"	HDH 24-GJR	08539202		5600 / 4900	7500 / 260	1100 / 800	3.5	44
	30"	HDH 30-GJR	08528602		6800 / 6000	8000 / 270	1100 / 800	4	48
	36"	HDH 36	08197802		6970	12000 / 325	1100	5.2	90
1 Year Warranty									
Industrial Oscillating 1/4	20"	ACH 20-O	08684802	OSCILLATING	3000 / 2600 / 2100	5000 / 200	1100 / 900 / 750	2.4	43
	24"	ACH 24-O	07963602		3800 / 3400 / 2700	6000 / 240	1100 / 900 / 750	2.5	44
	30"	ACH 30-O	07963702		4300 / 3800 / 3000	7200 / 250	1100 / 900 / 750	2.7	48

\*Measured 2 feet from face of fan

**HDH-36 Note: Wall mount only, mount included, unit imported to TPI specifications.**

**TPI offers six factory assembled and tested fan mounts that can be used with any of the non-oscillating TPI Industrial heads.**

# TPI Industrial Unassembled Circulators

## Features

- Unassembled packaged kits, include: motor, blade, guards & mount (pedestal or wall)
- Steel construction with silver/gray powder coated; steel motor housing painted black
- Direct drive, Totally Enclosed Air-Over (TEAO) motor generating up to 7,200-CFM's
- Aluminum 3-paddle blade system with steel hub and cast aluminum spider connections
- All models contain a pull-chain switch and 12' long SJT-Type cord with grounded plug
- All models contain self-locking retaining clips to secure front/rear grills and meet OSHA safety requirements
- Offered in Non-Oscillating (Stationary) and Oscillating fan heads in 20", 24" or 30" diameter sizes
- Oscillating models rotates in a 90° arc or can be locked in a fixed position
- Metal gears in the oscillating model allow the fan to operate at a maximum 30° downward tilt
- Pedestal pole adjusts the center of fan from 48" to 67" tall; bolts to 27" diameter steel dome with 5-bolts
- Motor warranty from 1 or 3-years
- Made in the U.S.A. with domestic and foreign components



**UHP-P Series**



**ACU-WO Series**

Oscillating Fan Head with Wall Mount



DIMENSIONS	
20"	22" Diameter x 14.5" Depth
24"	27" Diameter x 14.5" Depth
30"	33.5" Diameter x 14.5" Depth

**WARNING:** This product can expose you to chemicals including nickel which is known to the State of California to cause cancer, and chromium, which is known to the State of California to cause birth defects and/or reproductive harm. For more information go to [www.P65Warnings.ca.gov](http://www.P65Warnings.ca.gov).

## Motor Specifications

- 2-speed
- 1-Phase, 120V
- Ball bearing
- Frame size: 48
- Totally enclosed
- Permanent split capacitor
- Permanently lubricated
- ½" Shaft

## Standard Models

FAN TYPE		MAXIMUM DUTY	MAX AMPS	HIGH PERFORMANCE		MAX AMPS	INDUSTRIAL	MAX AMPS	OSCILLATING	MAX AMPS		
MOTOR	HP	1/3		1/3			1/4		1/4			
CFM Velocity Profile / Area Sq. Ft.	20"	---	---	---	---		5000 / 200		5000 / 200		2.4	
	24"	6000 / 240	2.8	6000 / 240	2.8		6000 / 240		6000 / 240		2.5	
	30"	7200 / 250	3.0	7200 / 250	3.0		7200 / 250		7200 / 250		2.7	
WARRANTY		3 YEARS		3 YEARS			1 YEAR		1 YEAR			
SIZE	TYPE of MOUNT	MFG CATALOG NUMBER	MFG MODEL NUMBER	MFG CATALOG NUMBER	MFG MODEL NUMBER	WT. (LBS)	MFG CATALOG NUMBER	MFG MODEL NUMBER	WT. (LBS)	MFG CATALOG NUMBER	MFG MODEL NUMBER	WT. (LBS)
20"	Pedestal Mount	---	---	---	---	---	08681402	ACU 20-P	72	08681602	ACU 20-PO	76
	Wall Mount	---	---	---	---	---	08681502	ACU 20-W	42	08681702	ACU 20-WO	46
24"	Pedestal Mount	08745202	UHP 24-PJR	07990002	UHP 24-P	75	07962302	ACU 24-P	75	07964002	ACU 24-PO	79
	Wall Mount	08745402	UHP 24-WJR	07990202	UHP 24-W	45	07962402	ACU 24-W	45	07964102	ACU 24-WO	49
30"	Pedestal Mount	08745302	UHP 30-PJR	07990102	UHP 30-P	73	07962802	ACU 30-P	73	07964202	ACU 30-PO	82
	Wall Mount	08745502	UHP 30-WJR	07990602	UHP 30-W	48	07962902	ACU 30-W	48	07964302	ACU 30-WO	52

# TPI Industrial Specialty Circulator Heads

## Features

- No cord-junction box provided for hard wiring
- Steel hub/spider aluminum paddle blades
- Coated steel guards
- Meets OSHA standards
- 1 year limited warranty
- Made in U.S.A. with domestic and foreign components

## Motor Specifications

- All 1 Speed (except 277V which is 2 Speed)
- Totally enclosed, permanently lubricated
- Ball bearing



**ACH-EX SERIES**



\*Listing applies to 277V models only

**IHP-H-277 Series**



**IHP-H-WD Series**

**WARNING:** This product can expose you to chemicals including nickel which is known to the State of California to cause cancer, and chromium, which is known to the State of California to cause birth defects and/or reproductive harm. For more information go to [www.P65Warnings.ca.gov](http://www.P65Warnings.ca.gov).

## Standard Models

GENERAL DESCRIPTION	MFG MODEL NUMBER	MFG CATALOG NUMBER	SIZE	CFM*		VELOCITY PROFILE CFM / Area Sq Ft	MOTOR			AMPS (HIGH)					WT. (LBS)					
				HIGH	LOW		HP	RPM	VOLTS	120v 1 ph	240v 1 ph	277v 1 ph	240v 3 ph	480v 3 ph						
Hazardous Location Class I Group D Class II Group F & G Unassembled Head	ACH 24-EX1	08551902	24"	4300		6000 / 240	1/4	1725	115/208 or 1-phase	5	2.6	---	---	---	66					
	ACH 30-EX1	08552002	30"	5400		7200 / 250										69				
	ACH 24-EX3	08552102	24"	4300		6000 / 240											208-230/460 or 3-phase	1.4	0.7	66
	ACH 30-EX3	08552202	30"	5400		7200 / 250														
240V / 480V 3-Phase Unassembled Head	ACH 24-TE3	08552302	24"	4300		6000 / 240	1/2	1075	208-230/460 or 3-phase	---	---	---	2.2	1.1	45					
	ACH 30-TE3	08552402	30"	5400		7200 / 250										48				
277 Volt Assembled Head	IHP 24-H-277	08541302	24"	4300	3900	6000 / 240	1/3	1125	277 1-phase	---	---	1	---	---	40					
	IHP 30-H-277	08542202	30"	5400	4700	7200 / 250										44				
Wash down rated 120V / 240V 1-Phase Assembled Head	IHP 20-H-WD	08721902	20"	3200		5200 / 220	1/3	1725	120 or 240 1-phase	4.5	2.2	---	---	---	46					
	IHP 24-H-WD	08541802	24"	4300		6000 / 240										48				
	IHP 30-H-WD	08541902	30"	5400		7200 / 250											52			

\*Measured 2 feet from face of fan

**Note: Wash down rated fan heads have heavy zinc coated guards - Use FDA white coated mounts shown on page 7 for food service applications**

# TPI Industrial Circulator Components

## Standard Models

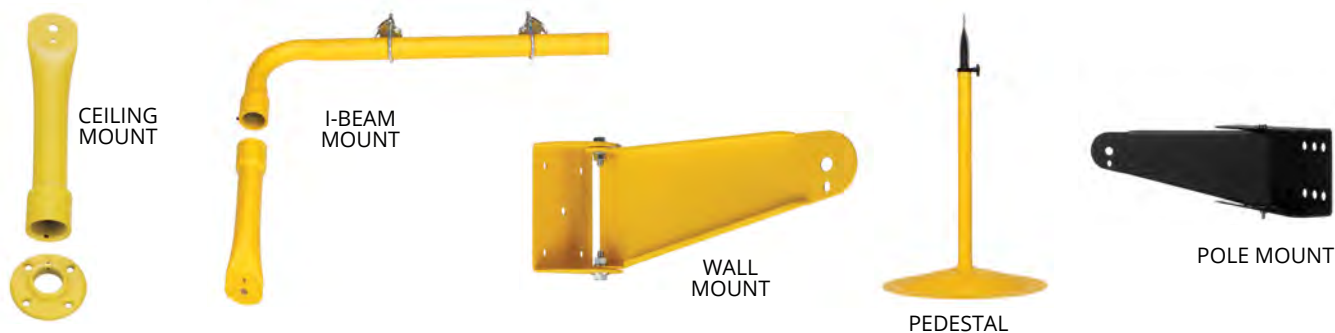
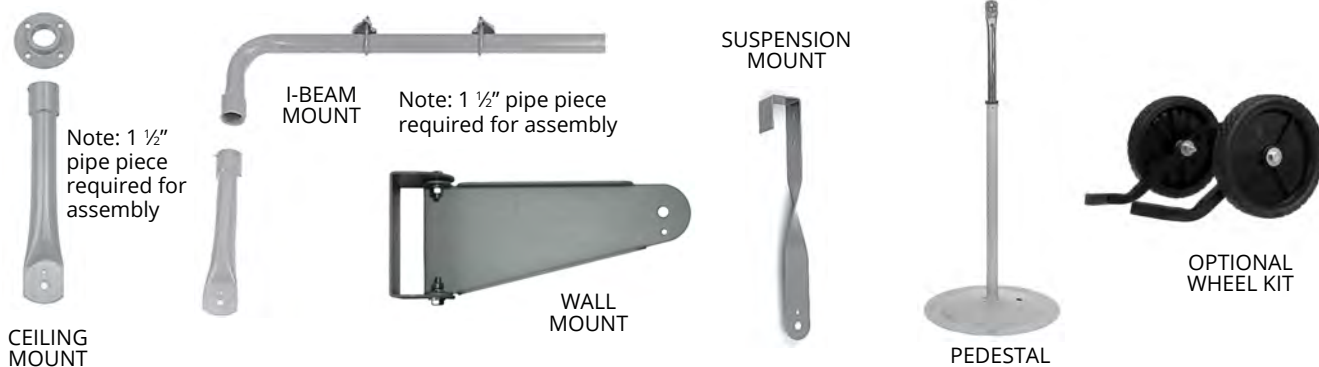

## Product Specifications

- Pedestal pole adjusts the center of fan from 48" to 67" and bolts to 27" diameter steel dome base with 5 bolts
- I-beam mount & ceiling mount require 1 1/2" or longer pipe nipple for assembly (not supplied)
- Pole mount attaches to 4", 6", or 8" with U-bolts (not supplied)
- Wheel kit and pole mount have an all black textured powder coated finish

## Mounts

TYPE	MFG CATALOG NUMBER	MFG MODEL NUMBER
YELLOW MOUNTS		
PEDESTAL POLE & BASE	07960902	HDM-P
WALL MOUNT	07961002	HDM-W
I-BEAM MOUNT	07961102	HDM-I
CEILING MOUNT	07961202	HDM-C
GRAY MOUNTS		
PEDESTAL POLE & BASE	07961802	ACM-P
WALL MOUNT	07961902	ACM-W
I-BEAM MOUNT	07962002	ACM-I
CEILING MOUNT	07962102	ACM-C
SUSPENSION MOUNT	07962202	ACM-S
POLE MOUNT	08681802	ACM-PM
WHEEL KIT	08681302	ACM-WK
FDA WHITE MOUNTS FOR USE WITH WASHDOWN FAN HEADS IN FOOD SERVICE APPLICATIONS		
PEDESTAL POLE & BASE	08682502	WACM-P
WALL MOUNT	08682602	WACM-W

## What to know when ordering TPI Air Circulators:

### 1) What is the operating voltage and phase?

- a. 120V (most common)
- b. 120V or 240V
- c. 277V
- d. 240 or 480V (offered in 3-phase)

### 2) How will you be mounting or operating this unit?

- a. Wall / Vertical Surface (Most Common)
- b. Floor – Pedestal Mount
- c. Pole Mount
- d. Ceiling
- e. Suspension Mount
- f. I-Beam Mount

### 3. What environment will this unit be operating in?

- a. Industrial – see TPI Series: HDH, IHP or ACH's
  - i. Dirty, dusty jobsites or harsh industrial environment
  - ii. Wet, high moisture, or wash down rated environment
  - iii. Hazardous Location – Class I Group D, Class II Groups F & G
- b. Commercial – see TPI Series; CACU's
  - i. Clean areas or non-dusty environment

### 4. Will you need the fan head to rotate?

- a. Oscillating
- b. Non-Oscillating Fan Heads

### 5. Do you want to order assembled fan heads?

- a. Assembled Fan Head
- b. Unassembled Fan Head (ACU, UHP & CACU Series)

### 6. Do you have a color preference?

- a. Safety Yellow – HDH Series
- b. Industrial Textured Gray Finish (Most popular)
- c. Black Semi-Gloss Powder Coated Finish (CACU-Series)

## Air Circulators - Motor Comparisons



### Commercial Motors - Open Vent Motors





**Open Ventilated Motor**

*Ideal for schools and office areas - clean and non-dusty environments*

- Offered in 1/4 HP & 1/3 HP
- Good output
- Open ventilated (air goes through the motor)
- Oscillating and Non-Oscillating
- Unassembled fan heads only
- 1-year limited warranty
- Ideal for Commercial Applications
  - offered in 120V models

### Industrial Motors - Totally Enclosed Motors (TEAO)





DESIGNED, ENGINEERED, TESTED, ASSEMBLED  
**PROUDLY IN THE USA**



**Totally Enclosed Motor**  
IMPROVES AIR QUALITY

Ideal for dirty and harsh industrial applications.

Specific models rated for even washdown and hazardous environments.

- Offered in 1/4 HP, 1/3 HP & 1/2 HP
- Higher quality and high CFP output
- Totally Enclosed Air Over (TEAO)
- Oscillating and Non-Oscillating
- Fully assembled fan heads
- No tools required to open grill assembly (retainer clips)
- 3-year warranty on 1/3 HP motors (5-year on 1/2 HP)
- Ideal for Commercial Applications
  - offered in 120, 240, 277 & 480V models
  - washdown and Hazardous Location Rated models

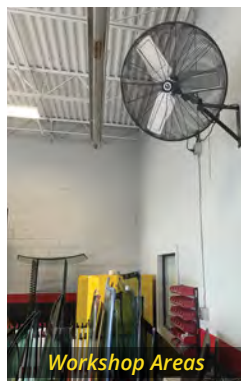
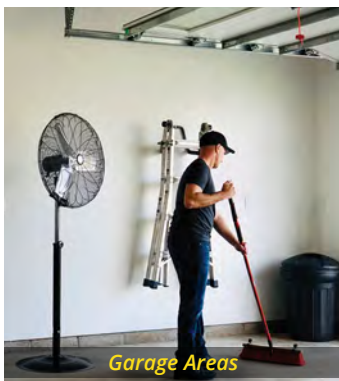

**Commercial Fan Applications**



**Industrial Fan Applications**



# TPI Commercial Circulators



These circulators should be used in clean and dry commercial applications - such as schools, shops, offices or warehouses.

## Commercial Circulator

Motor, blades, guards, and mount are packed and shipped in a single UPS-able carton.



PEDESTAL MOUNT



WALL MOUNT



### Features

- Black semi-gloss powder coated finish
- Pull chain switch
- SJT type 3 conductor, 9' long cord
- Coated steel guards with retaining clips
- Steel hub/spider aluminum paddle blades
- Pole adjusts center of fan from 43" to 60"
- Meets OSHA standards / 1-Year limited warranty
- Imported to TPI specifications

### Motor Specifications

- 1-Phase
- 1/4 HP, 1/3 HP on HD Models
- Ball bearing
- Open ventilated
- 120V
- 3-Speed
- Permanently lubricated
- Permanent split capacitor

**WARNING:** This product can expose you to chemicals including nickel which is known to the State of California to cause cancer, and chromium, which is known to the State of California to cause birth defects and/or reproductive harm. For more information go to [www.P65Warnings.ca.gov](http://www.P65Warnings.ca.gov).

## Standard Non-Oscillating Models

MFG CATALOG NUMBER	MFG MODEL NUMBER	SIZE	HP	TYPE	MOUNT TYPE	CFM*			VELOCITY PROFILE CFM / Area Sq Ft	AMPS (HIGH)	WT. (LBS)
						HIGH	MED	LOW			
08778002	CACU 20-P	20"	1/10	Non-Oscillating	Pedestal	1780	1600	1420	3300 / 125	1.4	52
08778102	CACU 20-W				Wall Mount						48
08706202	CACU 24-P	24"	1/4		Pedestal Mount	3400	3100	2800	5400 / 220	2.3	63
08706402	CACU 24-W				Wall Mount						43
08697402	CACU 30-P	30"	1/4		Pedestal Mount	4200	3800	3500	6700 / 240	2.4	66
08706302	CACU 30-W				Wall Mount						46
08761702	CACU 30-P-HD	30"	1/3		Pedestal Mount	5000	4600	4200	7000 / 250	3.60	56

\*Measured 2 feet from face of fan

Note: Stocked models may differ in appearance from photograph

# TPI Commercial Oscillating Fans

## Standard Oscillating Models



WALL MOUNT

MFG CATALOG NUMBER	MFG MODEL NUMBER	SIZE	HP	TYPE	MOUNT TYPE	CFM*			VELOCITY PROFILE CFM / Area Sq Ft	AMPS			WT. (LBS)
						HIGH	MED	LOW		HIGH	MED	LOW	
08748902	CACU 24-PO	24"	1/4	Oscillating	Pedestal Mount	3200	3000	2800	5100 / 230	1.45	1.15	1.1	68
08749102	CACU 24-WO				Wall Mount								48
08749002	CACU 30-PO	30"			Pedestal Mount	4200	3800	3500	6700 / 250	2.0	1.8	1.6	70
08749202	CACU 30-WO				Wall Mount								51
08761802	CACU 30-PO-HD	30"	1/3	Pedestal Mount	5000	4600	4200	7000 / 250	3.60	3.02	2.94	64	

**Notes:**

\*Measured 2 feet from face of fan

Stocked models may differ in appearance from photograph - sizes are nominal Units imported to TPI specifications.

**WARNING:** This product can expose you to chemicals including nickel which is known to the State of California to cause cancer, and chromium, which is known to the State of California to cause birth defects and/or reproductive harm. For more information go to [www.P65Warnings.ca.gov](http://www.P65Warnings.ca.gov).



# 36", 42", & 48" TPI Commercial Belt Drive Portable Blowers



**WARNING:** This product can expose you to chemicals including nickel which is known to the State of California to cause cancer, and chromium, which is known to the State of California to cause birth defects and/or reproductive harm. For more information go to [www.P65Warnings.ca.gov](http://www.P65Warnings.ca.gov).



### Features

- Rotary switch
- SJT type cord - 3 conductor - 8' long
- Aluminum 4-paddle blade
- Spiral wire front and rear guards
- Black powder coated 20 gauge steel housing
- Stationary non-swivel housing
- 5" rubber wheels
- Meets OSHA standards / 1 Year limited warranty
- Imported to TPI specifications

### Motor Specification

- 2-Speed
- 120V
- Ball bearing
- 1-Phase
- ODP type
- Permanently lubricated

### Standard Models

MFG CATALOG NUMBER	MFG MODEL NUMBER	MOTOR HP	CFM*		VELOCITY PROFILE	MAX AMPS	WT. (LBS)
			HIGH	LOW	CFM / Area Sq Ft		
08734702	CPB 36-B	1/3	5,400	4,600	8600 / 300	4.8	82
08706602	CPB 42-B	1/2	7,600	6,700	12000 / 320	6.5	93
08722702	CPB 48-B	3/4	8,800	7,700	14000 / 500	9.0	129

\*Measured 2 feet from face of fan

**Note: Photograph is a representation of stocked models. Actual model may vary in appearance**

# 24", 30", & 36" TPI Commercial Direct Drive Portable Blowers



### Features

- Rotary or rocker switch
- SJT type cord - 3 conductor
- Spiral wire front and rear guards
- Black powder coated 20 gauge steel housing
- 5" rubber wheels
- Meets OSHA standards
- 1 Year limited warranty
- Imported to TPI specifications

### Motor Specification

- 2-Speed
- 120 Volt
- Ball bearing
- 1-Phase
- Open ventilated
- Permanently lubricated

**WARNING:** This product can expose you to chemicals including nickel which is known to the State of California to cause cancer, and chromium, which is known to the State of California to cause birth defects and/or reproductive harm. For more information go to [www.P65Warnings.ca.gov](http://www.P65Warnings.ca.gov).

### Standard Models

MFG CATALOG NUMBER	MFG MODEL NUMBER	BASE TYPE	CFM*		VELOCITY PROFILE	MOTOR HP	MAX AMPS	CORD LENGTH	SWITCH	BLADES	WT. (LBS)
			HIGH	LOW	CFM / Area Sq Ft						
08753502	CPB 30-D	Floor	4,400	3,800	6700 / 250	1/5	3.6	6'	Rocker	Aluminum	52
08710302	CPBS 30-D	Swivel	4,400	3,800	6700 / 250	1/5	3.6	6'	Rocker	Aluminum	60
08722602	CPB 36-D	Floor	5,400	4,600	8500 / 300	1/3	3.6	10'	Rotary	Steel	70
08770102	CPBS 24-DHV	Swivel	3,400	2,900	5400 / 240	1/6	2.4	9'	Rotary	Aluminum	38

\*Measured 2 feet from face of fan

**Note: Photograph is a representation of stocked models. Actual model may vary slightly in appearance**

# 30", 36", & 42" TPI Industrial Direct Drive Portable Blowers



STANDARD MODEL



SWIVEL MODEL



Intertek

**WARNING:** This product can expose you to chemicals including nickel which is known to the State of California to cause cancer, and chromium, which is known to the State of California to cause birth defects and/or reproductive harm. For more information go to [www.P65Warnings.ca.gov](http://www.P65Warnings.ca.gov).

### Features

- Comes in sizes 30", 36", & 42"
- Rocker switch
- SJT type 3 conductor, 12' long cord
- Aluminum, 3 paddle blade
- Spiral, wire front and rear guards
- Corrosion and dent proof high density polyethylene housing
- 36" & 42" swivel model rotates 112.5° in 22 1/2° increments and locks in place with a steel locking pin
- Meets OSHA standards
- 1 Year limited warranty
- Made in U.S.A.

### Motor Specifications

- 120V, 1-Phase
- 36"-1/3HP 42"-1/2HP
- Ball bearing
- Permanent split capacitor
- 2-Speed on 30" model
- 1-Speed on 42" model
- Permanently lubricated
- Totally enclosed

### Standard Models

MFG CATALOG NUMBER	MFG MODEL NUMBER	FAN		WHEEL SIZE	MOTOR HP	CFM* / RPM		VELOCITY PROFILE CFM / Area Sq Ft	AMPS (HIGH)	WT. (LBS.)
		SIZE	TYPE			HIGH	LOW			
08211002	PBX 30-D	30"	STANDARD	8"	1/4	4400 / 1100	3800 / 950	7200 / 250	2.7	65
08213602	PBXS 30-D	30"	SWIVEL	10"						70
08211102	PBX 36-D	36"	STANDARD	8"	1/3	6500 / 1040	5400 / 950	11500 / 320	5.5	82
08213702	PBXS 36-D	36"	SWIVEL	10"						110
08211202	PBX 42-D	42"	STANDARD	10"	1/2	9,000 / 825		15000 / 340	7.9	102
08213802	PBXS 42-D	42"	SWIVEL	10"						128

\*Measured 2 feet from face of fan

**Note: Photograph is a representation of stocked models. Actual model may vary slightly in appearance**

# 48" TPI Industrial Direct Drive Portable Blowers



SWIVEL MODEL



Intertek

**WARNING:** This product can expose you to chemicals including nickel which is known to the State of California to cause cancer, and chromium, which is known to the State of California to cause birth defects and/or reproductive harm. For more information go to [www.P65Warnings.ca.gov](http://www.P65Warnings.ca.gov).

### Features

- Corrosion and dent proof high density polyethylene housing
- Rocker switch
- SJT type 3 conductor, 12' long cord
- Steel, 2 paddle blade
- Spiral, wire front and rear guards
- 10" wheels
- Swivel model rotates 112.5° in 22 1/2° increments and locks in place with a steel locking pin
- Meets OSHA standards
- 1 Year limited warranty
- Made in U.S.A.

### Motor Specifications

- 1-Phase
- 3/4 HP
- Ball bearing
- Permanent split capacitor
- 120V
- 1-Speed
- Permanently lubricated
- Totally enclosed

### Features

MFG CATALOG NUMBER	MFG MODEL NUMBER	SIZE	FAN TYPE	MOTOR HP	CFM* / RPM	VELOCITY PROFILE CFM / Area Sq Ft	AMPS (HIGH)	DIMENSIONS			WT. (LBS)
								"H"	"D"	"W"	
07997802	PB 48-D-OP	48"	STANDARD	3/4	11,800 / 825	14000 / 360	10.5	58.5	29	55.5	117
07998002	PBS 48-D-OP	48"	SWIVEL	3/4	11,800 / 825	14000 / 360	10.5	----	----	----	142

\*Measured 2 feet from face of fan

**Note: Photograph is a representation of stocked models. Actual model may vary slightly in appearance**

# 36", 42", & 48" TPI Industrial Belt Drive Portable Blowers



STANDARD MODEL



CORD WRAP INCLUDED WITH STANDARD MODEL

**⚠️ WARNING:** This product can expose you to chemicals including nickel which is known to the State of California to cause cancer, and chromium, which is known to the State of California to cause birth defects and/or reproductive harm. For more information go to [www.P65Warnings.ca.gov](http://www.P65Warnings.ca.gov).



SWIVEL MODEL



## Features

- Comes in sizes 36", 42", and 48"
- Rocker switch on 120V, Single Phase models
- SJT type 3 conductor, 12' long cord on 120V, Single Phase models / no cord on dual voltage models
- 4 paddle blade: 36" PBX / PBSX & HL have aluminum blade; 42" & 48" PBX / PBSX have steel blade
- Spiral, wire front and rear guards
- Corrosion and dent proof high density polyethylene housing
- 8" wheels (36" model), 10" wheels (42" & 48" models)
- Swivel model rotates 112.5° in 22.5° increments and locks in place with a steel locking pin
- External junction boxes on dual voltage models allow units to be wired for either voltage without removing guards
- Hazardous location models have explosion proof motors, metal housings, and external junction boxes rated for Class I, Group D and Class II, Groups E, F, & G
- Meets OSHA standards
- 1 year limited warranty
- Made in U.S.A.

## Motor Specifications

- 1-Speed
- Ball bearing
- Permanently lubricated

## Standard Models

MOTOR LISTING	SIZE	MOTOR				CFM**	VELOCITY PROFILE	STANDARD MODEL			SWIVEL MODEL		
		TYPE	HP	RPM	AMPS		CFM / Area Sq Ft	MFG CATALOG NUMBER	MFG MODEL NUMBER	WT. (LBS)	MFG CATALOG NUMBER	MFG MODEL NUMBER	WT. (LBS)
	36"	120 V 1 PH ODP	1/2	500	8.0	6,900	14000 / 360	08211402	PBX 36-B	120	08213302	PBXS 36-B	145
	42"		3/4	430	11.0	10,600	17500 / 420	08211502	PBX 42-B	135	08213402	PBXS 42-B	160
	48"		1	390	15.0	14,400	23500 / 550	08211602	PBX 48-B	155	08213502	PBXS 48-B	180
	36"	240/480 V 3 PH ODP	1/2	500	2.3 / 1.1	6,900	14000 / 360	08508602	PB 36-B-3	127	08509202	PBS 36-B-3	152
	42"		3/4	430	3.3 / 1.5	10,600	17500 / 420	08508702	PB 42-B-3	143	08509302	PBS 42-B-3	168
	48"		1	390	3.4 / 1.7	14,400	23500 / 550	08508802	PB 48-B-3	164	08509402	PBS 48-B-3	189
----	36"	120/240 V 1 PH EXP	1/2	500	7.8 / 3.9	6,900	14000 / 360	08508902	PB 36-B-HL*	135	08509502	PBS 36-B-HL	160
	42"		3/4	430	10.8 / 5.4	10,600	17500 / 420	08509002	PB 42-B-HL*	150	08509602	PBS 42-B-HL	175
	48"		1	390	13.2 / 6.6	14,400	23500 / 550	08509102	PB 48-B-HL*	173	08509702	PBS 48-B-HL	198

\*\*Measured 2 feet from face of fan \*Models have no listing.

**Note: Products listed in this section are custom built and subject to 100% cancellation/restocking charges.**

**Note: Photograph is a representation of stocked models. Actual model may vary slightly in appearance.**

# TPI Industrial Direct Drive Suspension Blowers

12



## Features

- On-Off rocker switch
- SJT type 3 conductor, 12' long cord
- Aluminum blade
- Powder coated spiral wire front and rear guards
- Corrosion and dent proof high density polyethylene housing
- Meets OSHA standards
- 1 year limited warranty
- Mounting chain not included
- Made in U.S.A.

## Motor Specifications

- 120V, 1-Phase
- Ball bearing
- Permanent split capacitor
- 2-Speed on 30" & 36" model
- 1-Speed on 42" model
- Permanently lubricated



**⚠ WARNING:** This product can expose you to chemicals including nickel which is known to the State of California to cause cancer, and chromium, which is known to the State of California to cause birth defects and/or reproductive harm. For more information go to [www.P65Warnings.ca.gov](http://www.P65Warnings.ca.gov).

## Standard Models

SIZE	MOTOR HP	MFG CATALOG NUMBER	MFG MODEL NUMBER	CFM*		VELOCITY PROFILE	RPM HIGH	AMPS HIGH	WT. (LBS)
				HIGH	LOW	CFM / Area Sq Ft			
30"	1/4	08213002	SBX 30-D	4,400	3,800	7200 / 250	1050	2.7	58
36"	1/3	08213102	SBX 36-D	6,500	5,400	11500 / 320	1050	5.5	70
42"	1/2	08213202	SBX 42-D	9,000		15000 / 340	825	7.9	99

\*Measured 2 feet from face of fan

# TPI Industrial Belt Drive Suspension Blowers



## Features

- ON-OFF rocker switch on 120V, 1-phase models
- SJT type 3 conductor, 12' long cord on 120V, 1-phase models
- No cord on dual voltage models
- Aluminum blade: SBX 36-B, SB 36-B-HL, SB 42-B-HL, SB 48-B-HL
- Steel blade: SBX 42-B, SBX 48-B
- Corrosion and dent proof high density polyethylene housing
- Powder coated spiral wire front and rear guards
- Meets OSHA standards
- 1 year limited warranty
- Mounting chain not included
- Made in U.S.A.

## Motor Specifications

- 120V, 1-Phase
- Ball bearing
- Permanent split capacitor
- 2-Speed on 30" & 36" model
- 1-Speed on 42" model
- Permanently lubricated

External junction boxes on dual voltage models allow units to be wired for either voltage without removing guards.

Hazardous Location models have explosion proof motors and external junction boxes rated for Class I, Group D, & Class II, Groups E, F & G, . (Metal housing and no switch)

## Standard Models

MFG CATALOG NUMBER	MFG MODEL NUMBER	SIZE	MOTOR		CFM**	VELOCITY PROFILE	RPM	AMPS	WT. (LBS)
			TYPE	HP		CFM / Area Sq Ft			
08212702	SBX 36-B	36"	115 V	1/2	6,900	14000 / 360	500	8	120
08212802	SBX 42-B	42"	1 PH	3/4	10,600	17500 / 420	430	11	135
08212902	SBX 48-B	48"	ODP	1	14,400	23500 / 550	390	15	155
08509802	SB 36-B-3	36"	230 / 460 V	1/2	6,900	14000 / 360	500	2.3 / 1.1	127
08509902	SB 42-B-3	42"	3 PH	3/4	10,600	17500 / 420	430	3.3 / 1.5	143
08510002	SB 48-B-3	48"	ODP	1	14,400	23500 / 550	390	3.8 / 1.9	164
08510102	SB 36-B-HL*	36"	115 / 230 V	1/2	6,900	14000 / 360	500	7.8 / 3.9	135
08510202	SB 42-B-HL*	42"	1 PH	3/4	10,600	17500 / 420	430	10.8 / 5.4	150
08510302	SB 48-B-HL*	48"	EXP	1	14,400	23500 / 550	390	13.2 / 6.6	173

Note: Products listed in this section are custom built and subject to 100% cancellation/restocking charges. Note: Photograph is a representation of stocked models. Actual model may vary slightly in appearance.

\*Models have no listing. \*\*Measured 2 feet from face of fan

# TPI Industrial Mini-Blowers



FLOOR MODEL



YOKE MOUNTED MODEL

\*\* Use in dirty or dusty environments  
\*\* Floor model or yoke mount available.

\*\* Bolt to any surface, or use with optional wall/ceiling mount.

### Features

- Floor models have rotary switch
- Yoke mounted models have pull chain switch
- SJT type 3 conductor, 10' long cord
- Aluminum blade
- Spiral, wire front and rear guards
- Corrosion and dent proof high density polyethylene housing
- Meets OSHA standards
- 1 year limited warranty
- Made in U.S.A. with domestic and foreign components

### Motor Specifications

- 1-Phase
- 1/4 HP
- Ball bearing
- Totally enclosed
- 120V
- 2-Speed
- Permanently lubricated
- Permanent split capacitor

MBM-W  
(Optional Wall/  
Ceiling Mount)



**WARNING:** This product can expose you to chemicals including nickel which is known to the State of California to cause cancer, and chromium, which is known to the State of California to cause birth defects and/or reproductive harm. For more information go to [www.P65Warnings.ca.gov](http://www.P65Warnings.ca.gov).

### Standard Models

MFG CATALOG NUMBER	MFG MODEL NUMBER	FAN		CFM* / RPM		VELOCITY PROFILE CFM / Area Sq Ft	DIMENSIONS			AMPS (High)	WT. (LBS)
		TYPE	SIZE	HIGH	LOW		"H"	"W"	"D"		
08743502	MB 24-DF	FLOOR STYLE	24"	3300 / 1140	2900 / 1070	5200 / 240	29 1/2"	28 1/2"	14 1/4"	1.8	52
08743602	MB 24-DY	YOKE STYLE					29"	28 1/2"	14 1/4"		
08743702	MB 30-DF	FLOOR STYLE	30"	4400 / 1040	3900 / 730	7000 / 250	38 1/2"	37 1/2"	14 1/2"	2.7	58
08743802	MB 30-DY	YOKE STYLE					38"	37 1/2"	14 1/2"		
07989002	MBM-W	OPTIONAL WALL/CEILING MOUNT FOR YOKE STYLE MINI-BLOWER									4

\*Measured 2 feet from face of fan

# TPI Industrial Heavy Duty Square Belt Drive Portable Blowers



4" CASTERS



**WARNING:** This product can expose you to chemicals including nickel which is known to the State of California to cause cancer, and chromium, which is known to the State of California to cause birth defects and/or reproductive harm. For more information go to [www.P65Warnings.ca.gov](http://www.P65Warnings.ca.gov).

### Features

- On-Off rocker switch
- SJT type 3 conductor, 12' long cord
- Steel blade
- Permanently lubricated bearings on blade drive shaft
- Powder coated front and rear guards
- Powder coated 20 gauge venturi
- 18 gauge galvanized steel housing
- Meets OSHA standards / 1 Year limited warranty
- Made in U.S.A.

### Motor Specifications

- 1-Phase
- Ball bearing
- Drip proof motor
- 120V
- 1-Speed
- Permanently lubricated
- 1/2" Shaft

### Standard Models

SIZE	MFG CATALOG NUMBER	MFG MODEL NUMBER	MOTOR			CFM*	VELOCITY PROFILE CFM / Area Sq Ft	DIMENSIONS			WT. (LBS)
			HP	RPM	AMPS			"H"	"W"	"D"	
36"	08683602	PCBT 36-B	1/2	1725	8.0	6,900	14,000 / 360	48 1/4"	40.38"	22 1/2"	120
42"	08683702	PCBT 42-B	3/4		11.0	10,600	17,500 / 420	56 1/2"	48.38"	22 1/2"	140
48"	08683802	PCBT 48-B	1		15.0	14,400	23,500 / 550	62 1/2"	54.38"	18 1/2"	185

\*Measured 2 feet from face of fan

# TPI Industrial High Velocity Blowers



## DIRECT DRIVE - SINGLE SPEED HIGH VELOCITY BLOWERS

(3) sizes to select from:  
18", 24" or 30" housing diameters



### Features

- ETL C/US listed for indoor spot cooling applications
- Heavy-duty yoke mounting bracket design with 2" square steel tubing frame
- Direct drive, Totally Enclosed Air-Over (TEAO) motor generating up to 9,000-CFM's
- Single speed, permanently lubricated ball-bearings with split capacitor
- TEAO motor operates on 60HZ and 1725-RPMs, and requires hard-wired connection to the supplied electrical enclosure located on the motor housing
- Aluminum 3-paddle blade system with steel hub and cast aluminum spider connections
- Non-Oscillating fan heads offered 18", 24" & 30" diameter sizes
- 2-year motor warranty

### Benefits

- Housing designed for all types of air circulating applications to provide directional high velocity air flow.
- Built-in rotating design allows the supplied mounting bracket to pivot 120° in (9) adjustment settings at 15° variations.
- Front & rear spiral wound grills are OSHA approved and have a black powder coated finish.
- All units are shipped fully assembled and ready for hard-wired connections
- TEAO motor has a Class B rating, with automatic thermal protection and ball bearing design for harsh environments; rated up to 115°F max. ambient temperature.
- Single and three phase options available in 120, 277 & 480V.

### All Steel Structure

2" square tubing

Adjustable bracket up to 120°

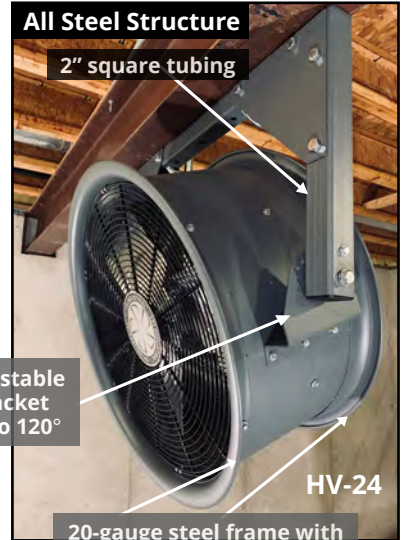

HV-24

20-gauge steel frame with welded venturi design on intake & discharge ends

### Specifications

- 1-Speed
- 1 Phase, 120V, 208/240V, 277V or 480V
- 3-Phase, 480V
- Ball bearing
- Totally enclosed, air over
- Permanent split capacitor/lubricate
- 1/2" Motor Shaft

### Applications

Units are ideal for warehouse, material handling, and high-shelf areas for directing high volumes of air flow down aisles, loading dock areas, conveyor systems, processing centers, workstations, jobsite, and all types of industrial operations for rugged environments.



HV-1 dock arm mount accessory plus HV-18 fan head

HV-30



HV-1

HV-3 Wall/Column Mount Accessory plus HV-30 Fan Head



# TPI Industrial High Velocity Blowers

## Standard Models

SIZE	MFG CATALOG NUMBER	MFG MODEL NUMBER	VOLTS	PH	AMPS (High)	HP	WATTS	RPM	CFM*	VELOCITY PROFILE CFM/Area Sq. Ft.	BLADE DIA.	DIMENSIONS (in.)			WT. (lbs.)
												L	W	H	
18"	08195602	HV-18-120V	120	1	3.4	1/2	373	1725	3000	5000 / 175	16"	13.5	27.4	26	45
	08195702	HV-18-208/240V	208/240	1	1.9										
	08195802	HV-18-277V	277	1	1.5										
	08195902	HV-18-480V	480	1	1.0										
	08197202	HV-18-480V-3	208-230/460	3	1.4 / 0.8										
24"	08196002	HV-24-120V	120	1	3.8	1/2	373	1725	5290	8500 / 275	22"	13.5	33.3	31.4	58
	08196102	HV-24-208/240V	208/240	1	2.1										
	08196202	HV-24-277V	277	1	1.7										
	08196302	HV-24-480V	480	1	1.1										
	08197302	HV-24-480V-3	208-230/460	3	1.5 / 0.8										
30"	08196402	HV-30-120V	120	1	7.6	1	746	1700	9000	14250 / 375	28"	16	38.9	39	85
	08196502	HV-30-208/240V	208/240	1	4.3										
	08196602	HV-30-277V	277	1	3.2										
	08196702	HV-30-480V	480	1	1.6										
	08197402	HV-30-480V-3	208-230/460	3	3.4 / 1.6										

\*Measured 2' from face of fan; Velocity is the highest recorded CFM

### Dimensions:

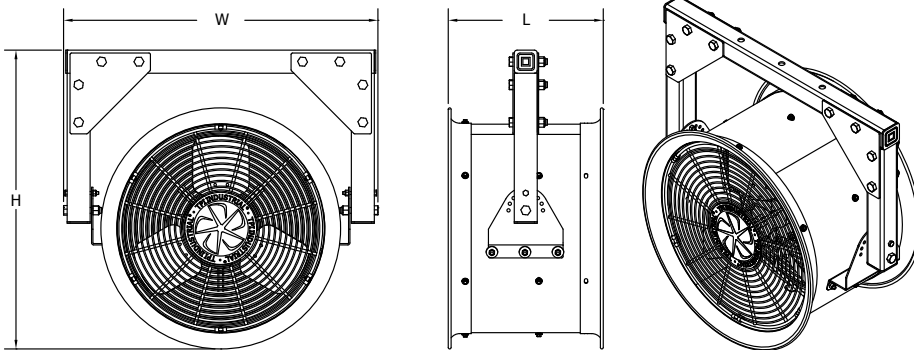

### Dock Swing Arm - 24" Reach



### Wall/Column Mount

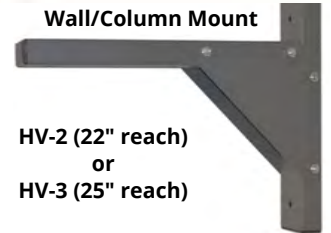

HV-2 (22" reach)  
or  
HV-3 (25" reach)

## Accessory Models

MFG CATALOG NUMBER	MFG MODEL NUMBER	TYPE	FITS MODEL SERIES
08197502	HV-1	Dock Arm, 24" Reach	HV-18
08197602	HV-2	Wall / Column Mount	HV-18 & HV-24
08197702	HV-3	Wall / Column Mount	ALL
08199002	HV418	Low Stand	HV-18
08199102	HV424		HV-24
08199202	HV430		HV-30
08199302	HV518	Medium Stand	HV-18
08199402	HV524		HV-24
08199502	HV530		HV-30
08199602	HV618	High Stand	HV-18
08199702	HV624		HV-24
08199802	HV630		HV-30
08199902	HV7DC1	Disconnect Switch	1-Phase
08200002	HV7DC3		3-Phase
08209802	HV8	Caster Kit (Qty.4)	ALL Heads/Stands



### Image Shown Includes

HV-24 (Fan Head)  
HV-5-24 (Medium Stand)  
HV-8 (Caster Kit)

**Note: All items must be ordered separately.**

**Note :** Stands do not include casters

Contact TPI customer Service for additional cost for mounting fan to the stand and wiring the disconnect prior to shipping.



# TPI Industrial Heavy Duty Direct Drive Blowers



LOW STAND



MEDIUM STAND



HIGH STAND

**WARNING:** This product can expose you to chemicals including nickel which is known to the State of California to cause cancer, and chromium, which is known to the State of California to cause birth defects and/or reproductive harm. For more information go to [www.P65Warnings.ca.gov](http://www.P65Warnings.ca.gov).

## Features

- Totally enclosed and explosion proof motors
- Explosion proof motors are Class 1, Div 1, Group D and Class 2, Div 1, Groups F & G
- Cast Aluminum props
- 14 gauge steel body and stand
- Acid resistant coating available
- Baked enamel coating
- 360° Swivel on high and medium stand units
- Meets federal OSHA requirements
- 1 year limited warranty

## NOTE:

Single phase motors are field convertible 115V / 230V  
 Three phase motors are field convertible 230V / 460V  
 Motors are set to lower voltage at the factory unless a request is made at time of order to set to the higher voltage

## Standard Models

SIZE	MFG MODEL NUMBER	HP	RPM	CFM	DB's @ 10'	WT. (LBS)		
						STAND		
						LOW	MED	HIGH
MODEL NUMBER SUFFIXES								
18"	MCD18-1/4	1/4	1725	3050	74	103	145	210
	MCD18-1/3	1/3	1725	3450	76	105	150	215
	MCD18-1	1	1725	4600	77	117	165	230
24"	MCD24-1/4	1/4	1725	5200	80	115	165	230
	MCD24-1/3	1/3	1140	5300	74	126	175	250
	MCD24-1/2	1/2	1725	6000	80	120	170	240
	MCD24-3/4	3/4	1140	6900	74	140	190	260
	MCD24-1	1	1725	7400	82	130	180	250
	MCD24-1 1/2	1.5	1725	8200	84	137	190	255
	MCD24-3	3	1725	10500	87	160	210	270
30"	MCD30-1/3	1/3	1140	6900	80	150	205	260
	MCD30-1/2	1/2	1725	8900	86	141	195	250
	MCD30-3/4	3/4	1140	10400	80	210	260	320
	MCD30-1	1	1140	11200	81	200	260	310
	MCD30-1 1/2	1.5	1725	12000	92	200	250	310
	MCD30-2	2	1140	14000	84	225	270	330
36"	MCD30-3	3	1725	16000	94	220	265	325
	MCD36-1	1	1140	13000	82	250	320	375
	MCD36-1 1/2	1.5	1725	14850	88	250	320	375
	MCD36-2	2	1140	17500	82	255	325	380
	MCD36-3	3	1725	18500	90	260	330	390
42"	MCD36-5	5	1725	23000	94	260	330	390
	MCD42-2	2	1140	19500	85	315	415	565
	MCD42-5	5	1725	27000	98	320	420	570
48"	MCD48-5	5	1140	32000	92	500	620	710
	MCD48-7 1/2	7.5	1140	37000	105	625	745	835
	MCD48-10	10	1140	41000	105	682	800	890
60"	MCD60-3	3	690	35000	87	690	855	965
	MCD60-5	5	690	45000	87	730	895	1005
	MCD60-7 1/2	7.5	870	47000	90	945	1110	1220
	MCD60-10	10	870	57200	91	1035	1200	1310
	MCD60-15	15	870	60750	92	1080	1245	1355

## Manual Starter Switches

MFG MODEL NUMBER		H.P. RATING
1 PH	3 PH	
SW-1/4	SW-1/4-3	1/4-1/3
SW-1/2	SW-1/2-3	1/2-3/4
SW-1	SW-1-3	1
SW-1 1/2	SW-1 1/2-3	1.5
-----	SW-2-3	2
-----	SW-3-3	3
-----	SW-5-3	5
-----	SW-7 1/2-3	7.5

## Polyolifin Casters

MFG MODEL NUMBER	FAN SIZE	WHEEL SIZE	WT. (LBS)
CAS - 18	18" - 30"	4"	10
CAS - 48	36" - 48"	5"	14

(FOR LOW & MEDIUM STAND)  
 4 CASTERS - 2 LOCKING

Note: Products listed in this section are custom built and subject to 100% cancellation/restocking charges

# TPI Industrial Heavy Duty Permanent Mount Direct Drive Blowers



1-WAY SWIVEL



2-WAY SWIVEL

**⚠ WARNING:** This product can expose you to chemicals including nickel which is known to the State of California to cause cancer, and chromium, which is known to the State of California to cause birth defects and/or reproductive harm. For more information go to [www.P65Warnings.ca.gov](http://www.P65Warnings.ca.gov).

## Features

- Front and rear spiral guards
- Explosion proof motors are Class 1, Div 1, Group D and Class 2, Div 1, Groups F & G
- Cast aluminum props
- 14 gauge steel body and stand
- Meets federal OSHA requirements
- 1 year limited warranty

## NOTE:

**Single Phase motors are field convertible 115V / 230V**  
**Three Phase motors are field convertible 230V / 460V**  
**Motors are set to lower voltage at the factory unless a request is made at time of order to set to the higher voltage**

## Standard Models

BLADE SIZE	MFG MODEL NUMBER	HP	RPM	CFM	DB'S @ 10'	WT. (LBS)	
						1-WAY SWIVEL	2-WAY SWIVEL
MODEL NUMBER SUFFIXES							
18"	MCD18-1/4	1/4	1725	3050	74	130	140
	MCD18-1/3	1/3	1725	3450	76	135	145
	MCD18-1	1	1725	4600	77	145	155
24"	MCD24-1/4	1/4	1725	5200	80	145	155
	MCD24-1/3	1/3	1140	5300	74	155	165
	MCD24-1/2	1/2	1725	6000	80	150	160
	MCD24-3/4	3/4	1140	6900	74	170	180
	MCD24-1	1	1725	7400	82	160	170
	MCD24-1 1/2	1.5	1725	8200	84	165	175
	MCD24-3	3	1725	10500	87	190	200
30"	MCD30-1/3	1/3	1140	6900	80	180	190
	MCD30-1/2	1/2	1725	8900	86	170	180
	MCD30-3/4	3/4	1140	10400	80	240	250
	MCD30-1	1	1140	11200	81	230	240
	MCD30-1 1/2	1.5	1725	12000	92	230	240
	MCD30-2	2	1140	14000	84	255	265
36"	MCD30-3	3	1725	16000	94	250	260
	MCD36-1	1	1140	13000	82	295	305
	MCD36-1 1/2	1.5	1725	14850	88	295	305
	MCD36-2	2	1140	17500	82	300	310
	MCD36-3	3	1725	18500	90	315	325
	MCD36-5	5	1725	23000	94	305	315

## Exhaust Ventilation Guide

Minute air change chart for commercial and industrial applications

Place	Typical	Range
Assembly	(6)	2-10
Auditoriums	(6)	1-20
Bakeries	(2)	1-3
Banks	(6)	3-10
Bars	(4)	2-5
Barns	(15)	10-20
Boiler Rooms	(2)	1-3
Bowling Alley	(3)	1-5
Cafeteria	(4)	3-5
Churches	(6)	2-10
Classrooms	(6)	4-8
Compressor Rooms	(2)	1-3
Dance Halls	(6)	2-10
Dairies	(4)	2-5
Dormitories	(6)	4-8
Dry Cleaning Plant	(3)	1-5

CFM Required for Ventilation =  $\frac{\text{Building Cubic Feet}}{\text{Minutes Per Air Change}}$

Place	Typical	Range	Place	Typical	Range
Engine Rooms	(3)	1-5	Mills	(4)	2-5
Factories	(7)	4-10	Packing Houses	(4)	3-5
Foundries	(5)	2-8	Plants	(7)	4-10
Garages	(7)	4-10	Plating Plants	(4)	2-5
Generating Plants	(4)	2-5	Print Shops	(7)	4-10
Glass Plants	(2)	1-3	Restaurants	(6)	2-10
Gymnasiums	(6)	2-10	Rest Rooms	(7)	4-10
Hallways	(8)	4-12	Schools	(7)	4-10
Kitchens (Comm.)	(3)	1-5	Stores	(7)	4-10
Laboratories	(3)	1-5	Theaters	(6)	4-8
Libraries	(4)	2-5	Transformer Rooms	(3)	1-5
Laundries	(2)	1-3	Turbine Rooms	(4)	2-5
Locker Rooms	(6)	2-10	Waiting Rooms	(12)	10-15
Machine Shops	(4)	2-5	Warehouses	(7)	4-10
Markets	(6)	2-10	Welding Rooms	(3)	1-4

Note: Products listed in this section are custom built and subject to 100% cancellation/restocking charges

# Industrial Workstation Floor Fans



## Features

- ETL C/US listed for indoor spot cooling applications
- Steel construction with a silver & black powder coated finish
- Direct drive totally enclosed air-over (TEAO) motor generating up to 6000-CFM's (F24-TE-HV)
- Three-speed, 120V, 1/8, 1/4, or 1/12-HP, sleeve bearing, permanently lubricated, TEAO motor operates at 60HZ and 1660-RPMs
- Rotary switch located on the back grill
- 10' long SJT type grounded 3-conductor cordset with molded plug
- Aluminum 3-paddle blade system with steel hub and cast aluminum spider connections
- 1-year manufacturer's warranty



## Motor Specifications

- Sleeve bearing
- Totally enclosed
- 1-Phase, 120V
- 3-Speed
- Permanently lubricated
- Frame size: 42
- 5/16" Shaft

**⚠ WARNING:** This product can expose you to chemicals including nickel which is known to the State of California to cause cancer, and chromium, which is known to the State of California to cause birth defects and/or reproductive harm. For more information go to [www.P65Warnings.ca.gov](http://www.P65Warnings.ca.gov).



FAN HEAD  
TILTS 360°



MAX CFM  
6,000



3 SPEEDS

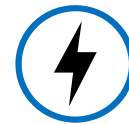

120V ;  
1-PHASE

## Standard Models

SIZE	MFG CATALOG NUMBER	MFG MODEL NUMBER	FAN TYPE	MOTOR HP	CFM** / RPM			VELOCITY PROFILE CFM / Area Sq Ft	DIMENSIONS			MAX AMPS	WT. (LBS)
					HIGH	MED	LOW		"H"	"W"	"D"		
12"	07986102	F-12-TE	FLOOR MODEL	1/12	900 / 1590	800 / 1380	700 / 1080	1400 / 50	15 1/4"	14 1/2"	9 1/2"	1.1	13
18"	07972902	F-18-TE		1/8	1800 / 1660	1500 / 1550	1300 / 1370	2900 / 125	20 1/2"	20 1/2"	10 1/2"	2.2	20
24"	08528502	F-24-TE		1/8	2100 / 1634	1900 / 1484	1600 / 1200	3500 / 150	26"	26"	10 1/2"	2.4	23
24"	08775402	F-24-TE-HV		1/4	3800 / 1100	3600 / 950	3400 / 800	6000 / 240	26"	26"	10 1/2"	2.7	25
18"	07973002	F-18H-TE*	HIGH STAND	1/8	1800 / 1660	1500 / 1550	1300 / 1370	2900 / 125	53"	25"	27"	2.2	27
24"	08540602	F-24H-TE*		1/8	2100 / 1634	1900 / 1484	1600 / 1200	3500 / 150	53"	30"	27"	2.4	30

\*\*Measured 2 feet from face of fan

### FLOOR MODELS

F-24-TE



F-18-TE



F-12-TE



# Industrial Mounted Workstation Fans



**WARNING:** This product can expose you to chemicals including nickel which is known to the State of California to cause cancer, and chromium, which is known to the State of California to cause birth defects and/or reproductive harm. For more information go to [www.P65Warnings.ca.gov](http://www.P65Warnings.ca.gov).

FAN SIZE	DIMENSIONS		
	"H"	"W"	"D"
12"	15 1/2"	14 1/2"	9 1/2"
18"	21 1/2"	20 1/2"	10 1/2"
24"	27"	26"	10 1/2"

## Features

- Pull chain switch
- Head rotates 360° vertically and horizontally
- Coated steel guards
- SJT type 3 conductor, 10' long cord
- Steel hub/spider aluminum paddle blades
- Meets OSHA standards / 1 Year limited warranty
- Imported to TPI specifications



## Motor Specifications

- Sleeve bearing
- Totally enclosed, permanently lubricated
- Frame size: 42
- 3-Speed
- 1-Phase, 120V
- 5/16" (12" fan only) and 1/2" shaft

FAN SIZE	MFG CATALOG NUMBER	MFG MODEL NUMBER	MOTOR HP	CFM* / RPM			VELOCITY PROFILE CFM / Area Sq Ft	MAX AMPS	WT. (LBS)
				HIGH	MED	LOW			
12"	07986002	U-12-TE	1/12	900 / 1590	800 / 1380	700 / 1080	1400 / 50	1.1	13
18"	07972802	U-18-TE	1/8	1800 / 1660	1500 / 1550	1300 / 1370	2900 / 125	2.2	20
24"	08540702	U-24-TE	1/8	2100 / 1634	1900 / 1484	1600 / 1200	3500 / 150	2.4	23
24"	08775502	U-24-TE-HV	1/4	3800 / 1100	3600 / 950	3400 / 800	6000 / 240	2.7	25

PIPE DIAMETER	MFG CATALOG NUMBER	MFG MODEL NUMBER
1"	08512402	PM-1
1 1/2"	08512502	PM-1.5
2"	08512602	PM-2
2 1/2"	08512702	PM-2.5
3"	08512802	PM-3

\*Measured 2 feet from face of fan

**Note: Mount with one bolt or lag screw to walls, ceilings, work benches, machines or any surface.**

FAN SIZE	MFG CATALOG NUMBER	MFG MODEL NUMBER	MOTOR HP	CFM* / RPM			MAX AMPS	DESCRIPTION
				HIGH	MED	LOW		
12"	08216102	U-12-TE-W	1/12	900 / 1590	800 / 1380	700 / 1080	1.1	12" Industrial Mounted Workstation Fan w/ Mounting Arm
18"	08216202	U-18-TE-W	1/8	1800 / 1660	1500 / 1550	1300 / 1370	2.2	18" Industrial Mounted Workstation Fan w/ Mounting Arm



## Workstation Mounting Arms

MFG CATALOG NUMBER	MFG MODEL NUMBER	DESCRIPTION
08215902	WCM-W-10	WORKSTATION MOUNTING ARM, 6" - 10"
08216002	WCM-W-14	WORKSTATION MOUNTING ARM, 10" - 14"

# Outdoor Rated Yoke Mount Fans



**WARNING:** This product can expose you to chemicals including nickel which is known to the State of California to cause cancer, and chromium, which is known to the State of California to cause birth defects and/or reproductive harm. For more information go to [www.P65Warnings.ca.gov](http://www.P65Warnings.ca.gov).

## Features

- Direct drive totally enclosed motor
- Pull chain switch
- Head rotates 360° vertically and horizontally
- Knobs allow for 180° vertical rotation
- Coated black finish steel guards
- Steel yoke mounting bracket
- All black finish with aiming handle
- SJT type 3 conductor, 10' long cord
- Steel hub/spider aluminum 3-paddle blades
- Meets OSHA standards / 1 yr limited warranty
- Imported to TPI specifications

## Motor Specifications

- Sleeve bearing
- Totally enclosed, permanently lubricated
- Frame size: 42
- 3-Speed
- 1-Phase, 120V
- 1/2" shaft



## Standard Models

FAN SIZE	MFG CATALOG NUMBER	MFG MODEL NUMBER	MOTOR HP	RPM	CFM			VELOCITY PROFILE CFM/Area Sq. Ft.	MAX AMPS	WT. (LBS)
					HIGH	MED	LOW			
18"	08194502	U-18-TE-HD	1/10	1625	1900	1500	1300	3100 / 125	1.1	20
24"	08211802	U-24-TE-HD	1/4	1625	3800	3600	3400	6000 / 240	2.4	28

\*Measured 2 feet from face of fan

# TPI Commercial Floor Fans

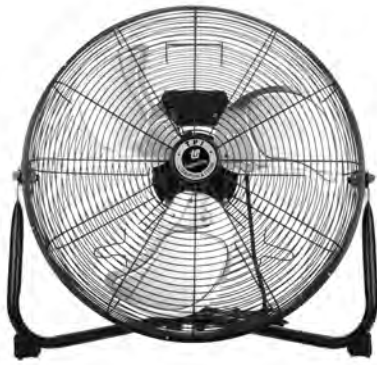

CF-20



**WARNING:** This product can expose you to chemicals including nickel which is known to the State of California to cause cancer, and chromium, which is known to the State of California to cause birth defects and/or reproductive harm. For more information go to [www.P65Warnings.ca.gov](http://www.P65Warnings.ca.gov).

## Features

- Rotary switch
- SJT type cord - 3 conductor - 7' long
- Aluminum blade
- Coated steel guards with retaining clips
- Meets OSHA standards / 1 Year limited warranty
- Imported to TPI specifications

## Motor Specification

- 3-Speed
- 120V
- Sleeve bearing
- 1-Phase
- Open ventilated
- Permanently lubricated

## Standard Models

MFG CATALOG NUMBER	MFG MODEL NUMBER	SIZE	TYPE	MOTOR HP	CFM			MAX AMPS	WT. (LBS)
					HIGH	MED	LOW		
08723002	CF-12	12"	FLOOR	1/12	1050	875	750	0.6	10
08723102	CF-18	18"	FLOOR	1/5	1600	1480	1380	1.4	16
08706502	CF-20	20"	FLOOR	1/5	1725	1600	1480	1.9	18

Units should be used in clean, dry, commercial applications. **Note: Photograph is a representation of stocked models. Actual model may vary in appearance.**

# Workstation Oscillating Office Fans



STAND FAN

DESK FAN



## Features

- 3-speed oscillating fans with push button controls
- 3 conductor SPT cord & plug
- White powder coated wire mesh guards
- White plastic housing and blade
- Stand fan extends to 40" height
- Meets OSHA standards / 1 Year limited warranty
- Imported to TPI specifications

**WARNING:** This product can expose you to chemicals including nickel which is known to the State of California to cause cancer, and chromium, which is known to the State of California to cause birth defects and/or reproductive harm. For more information go to [www.P65Warnings.ca.gov](http://www.P65Warnings.ca.gov).

## Standard Models

SIZE	MFG CATALOG NUMBER	MFG MODEL NUMBER	FAN TYPE	SPEEDS	CFM HIGH	AMPS HIGH	WT. (LBS)
12"	08513002	ODF-12	DESK	3	860	0.4	5.4
16"	08513102	ODF-16	DESK	3	1530	0.5	8.5
16"	08513202	OSF-16	STAND	3	1530	0.5	15.5

# Workstation Wall Mount Fan With Pivoting Arm

## 18" HIGH VELOCITY FAN MOUNTED ON 24", 40", or 60" PIVOTING ARMS



**WARNING:** This product can expose you to chemicals including nickel which is known to the State of California to cause cancer, and chromium, which is known to the State of California to cause birth defects and/or reproductive harm. For more information go to [www.P65Warnings.ca.gov](http://www.P65Warnings.ca.gov).

### Mounting Arm Features

- 1 1/2" square, 14 gauge, steel tubing
- 3" x 5" x 3/16" mounting plate attaches with (4) 3/8" bolts
- 5' long, 18/5 SJTW conductor cord and NEMA 5-15 grounded plug
- Dual electrical outlets embedded in arm to allow connection of modular fan and optional light
- Made in U.S.A. with domestic and foreign components



### Modular Fan Features

- 18" high velocity circulator, with 3 speed, 1/8 HP, 115V, 1-Phase permanently lubricated, totally enclosed, PSC motor
- Modular fan plugs into electrical outlet on arm
- Coated steel guards / Aluminum blades
- Meets OSHA standards / 1 year limited warranty

Use on loading docks to cool off workers entering hot truck trailers.

Use at factory workstations to cool off people or the machines.

### Standard Models

MFG CATALOG NUMBER	MFG MODEL NUMBER	FAN SIZE	ARM LENGTH	FAN CFM*			VELOCITY PROFILE	MAX AMPS	WT. (LBS)
				HIGH	MED	LOW	CFM / Area Sq Ft		
08009102	24-LDF-TE	18"	24"	1800	1500	1300	2900 / 125	2.2	31
08009202	40-LDF-TE	18"	40"						38
08009302	60-LDF-TE	18"	60"						44

\*Measured 2 feet from face of fan

### Loading Dock Arm Fan

MFG CATALOG NUMBER	MFG MODEL NUMBER	FAN SIZE	FAN CFM*			MAX AMPS	WT. (LBS)
			HIGH	MED	LOW		
07971802	LDF-18-TE	18"	1800	1500	1300	2.2	20

### Optional Modular Lights



DKL-INC



### Light Features

- Plugs into embedded outlet in arm
- On/off switch and wire guard included
- LED bulb included with DKLED-30W-SP
- Safety yellow finish for higher visibility

### Standard Models

MFG CATALOG NUMBER	MFG MODEL NUMBER	LIGHT HEAD TYPE	MAX WATTS	MAX LUMENS	AVE. BULB LIFE (HRS)	WT. (LBS)
04465602	DKL-INC	Incandescent	300	3,700	2,000	5

**WARNING:** This product can expose you to chemicals including nickel which is known to the State of California to cause cancer, and chromium, which is known to the State of California to cause birth defects and/or reproductive harm. For more information go to [www.P65Warnings.ca.gov](http://www.P65Warnings.ca.gov).

# Low Velocity "Special Application" Workstation Fan

### Features

- 12" aluminum blade air circulator for wall, ceiling, or bench mount
- 120V, 1-phase, 1/12HP with direct wire electrical connection
- Toggle switch with 2-speed control generating up to 1200 CFM
- All metal construction with a gray powder coated finish
- Fan head tilts 90° in horizontal and vertical plane
- Conforms to U.S. Navy Specification MIL-DTL-68G
- Meets OSHA standards / 1-year limited warranty
- Made in the U.S.A. with domestic and foreign components



WALL MOUNT

**WARNING:** This product can expose you to chemicals including nickel which is known to the State of California to cause cancer, and chromium, which is known to the State of California to cause birth defects and/or reproductive harm. For more information go to [www.P65Warnings.ca.gov](http://www.P65Warnings.ca.gov).



BENCH MOUNT



CEILING MOUNT

### Standard Models

SIZE	MFG CATALOG NUMBER	MFG MODEL NUMBER	MOTOR HP	CFM* / RPM		VELOCITY PROFILE	AMPS HIGH	WT. (LBS)
				HIGH	LOW	CFM / Area Sq Ft		
12"	08708902	N-12	1/12	800 / 1350	600 / 1000	1200 / 40	0.6	12

\*Measured 2 feet from face of fan

# Industrial Ceiling Fans

## Features

- 120-Volt / single phase, 60HZ electrical service
- Permanently sealed double radial ball bearing PSC AC motor provides maintenance free and quiet operation
- Low energy consumption – high efficiency performance
- White powder coated finish on steel motor housing & downrod
- White polymer 3-paddle blade system designed for quiet operation
- Includes 24" stainless steel safety cable kit
- Easy to mount to the supplied steel J-Hook connection
- Satisfies the U.S. Department of Energy's "Energy Guide" requirements
- E-CF models contain (4) 24" long lead wires for forward/reverse direct wire options providing year round operation in downflow or upflow direction
- E60-CFC has 3-speeds, includes cord/controller & IP65 rated equivalent for wet locations
- ETL Listed for USA & Canada / 5-year limited warranty



Models: E56-CF or E60-CF

Forward / Reverse wiring options



Model: E60-CFC

Indoor / Outdoor Rated  
Plug & Play Install  
Includes Speed Controller



## Motor Specifications

- 1-Phase, 120V
- Permanent sealed
- Ball bearing PSC AC Motor

• Energy Consumption:

Model #	Amps	Watts
E-56CF	0.70	85
E-60CF	0.70	90
E-60CFC	0.80	95

**WARNING:** This product can expose you to chemicals including nickel which is known to the State of California to cause cancer, and chromium, which is known to the State of California to cause birth defects and/or reproductive harm. For more information go to [www.P65Warnings.ca.gov](http://www.P65Warnings.ca.gov).



## Standard Models

MFG CATALOG NUMBER	MFG MODEL NUMBER	BLADE DIAMETER	AIRFLOW OPTIONS	DOWNROD LENGTH	MAX CFM	MOTOR RPM	MOTOR TYPE	CORD INCLUDED	SPEED CONTROLLER	WEIGHT (LBS.)
08198202	E-56CF	56"	Forward/Reverse	18"	7,775	290	Moisture Rated	None	Sold Separately	22
08198302	E-60CF	60"	Forward/Reverse	18"	8,434	260	Moisture Rated	None	Sold Separately	22
08198402	E-60CFC	60"	Down Draft	24"	9,630	250	Wet Rated	Yes	Included; 3-Speed	28

## Accessories

MFG CATALOG NUMBER	MFG MODEL NUMBER	TYPE	VOLTS	MAX AMPS	VARIABLE CONTROL KNOB	REVERSING SWITCH	# OF FANS	FOR USE WITH
07994102	KBWC-110K	Solid State Variable Speed Controllers	120	10	Yes w/ 3" X 5" Aluminum Plate **	No	1-10	All 3-Models
08666802	KBWC-15SK			5		Yes	1-5	E-56CF & E60CF
08210602	DR36	Down Rod Extender	36" long, steel, white finish, 3/4" diameter					All 3-Models

\*\* Fits 2" x 4" Opening

## How to Determine the Total # of Ceiling Fans Needed

Ceiling Height (feet)	Coverage Area (square feet)
10 - 11	600
12 - 13	800
14 - 15	950
16 - 17	1100
18 - 19	1300
20 - 21	1450

### What to Measure:

Total Square Footage (L x W)  
Maximum Ceiling Height

### Small Area Example:

If you have a 3,000 square foot facility with 16' ceilings:

**Calculation** (Total Sq.Ft. / Coverage Area): 3,000/1,100 = 2.73

**Total # of fans needed = 3**

### Large Area Example:

If you have a 10,000 square foot facility with 13' ceilings:

**Calculation** (Total Sq.Ft. / Coverage Area): 10,000/800 = 12.5

**Total # of fans needed = 12** (See chart for layout)

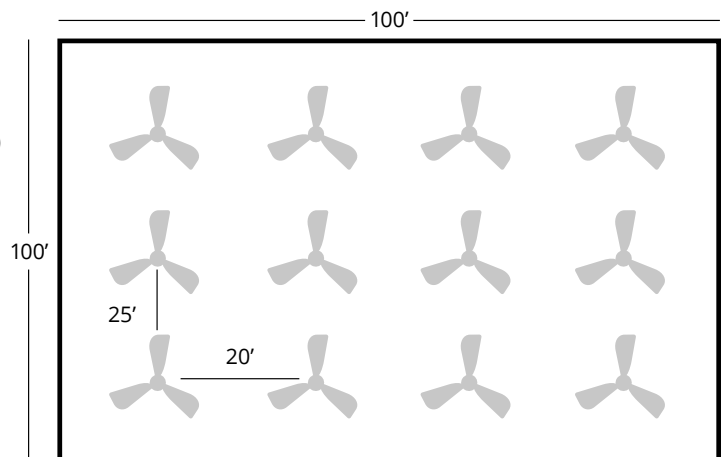

# Shutter Mounted Direct Drive Exhaust Fans

## Features

- Can be installed from inside wall
- Eliminates need for external framing and shutter
- Pull chain switch
- No Cord-Junction box provided for direct wiring
- Aluminum blade
- Steel spiral wire guards
- Made in U.S.A. with domestic and foreign components.
- See sizing chart on page 17

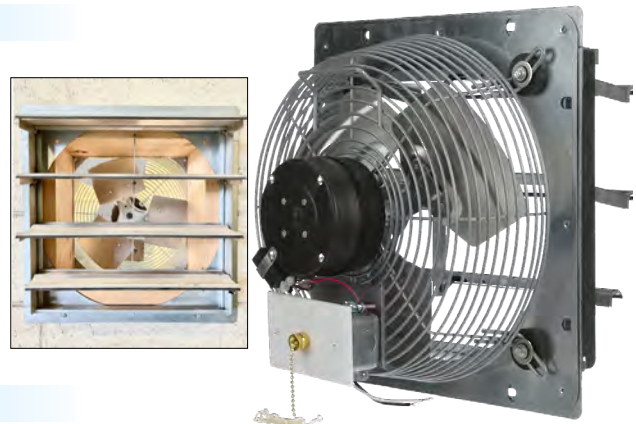

Rear View

## Motor Specifications

- 120V, 1-Phase, totally enclosed, permanently lubricated
- 1/12 HP motor is 3-Speed sleeve bearing permanent split capacitor
- 1/8 HP motor is 3-Speed sleeve bearing permanent split capacitor
- 1/4 HP motor is 2-Speed ball bearing permanent split capacitor

**Note:** Rough-in hole size is 1/2" inch larger than fan blade size

**WARNING:** This product can expose you to chemicals including nickel which is known to the State of California to cause cancer, and chromium, which is known to the State of California to cause birth defects and/or reproductive harm. For more information go to [www.P65Warnings.ca.gov](http://www.P65Warnings.ca.gov).

## Standard Models

FAN SIZE	MFG CATALOG NUMBER	MFG MODEL NUMBER	HP	CFM / RPM			AMPS HIGH	WT. (LBS)
				HIGH	MED	LOW		
10"	08689902	CE 10-DS	1/12	680 / 1560	540 / 1250	460 / 1080	1	11
12"	07986202	CE 12-DS	1/12	825 / 1560	710 / 1250	560 / 1080	1.1	16
14"	08690002	CE 14-DS	1/8	1520 / 1660	1400 / 1550	1250 / 1370	2	17
16"	08690102	CE 16-DS	1/8	2100 / 1660	1900 / 1550	1700 / 1370	2.1	18
18"	07986302	CE 18-DS	1/8	2300 / 1660	2100 / 1050	1850 / 1370	2.2	25
20"	08690202	CE 20-DS	1/4	2925 / 1140	-	2380 / 1070	2.3	34
24"	07986402	CE 24-DS	1/4	3400 / 1140	-	2770 / 1070	2.5	47
30"	07986502	CE 30-DS	1/4	3950 / 1140	-	3080 / 1070	2.7	54

## Dimensions (Inches)

SIZE	DEPTH	DIMENSIONS		
		"A"	"B"	"C"
10"	5.81"	13.125"	10"	12.375"
12"	7.18"	15.125"	12"	14.375"
14"	7.18"	17.125"	14"	16.375"
16"	7.18"	19.125"	16"	18.250"
18"	7.18"	21.125"	18"	21.750"
20"	7.18"	23.125"	20"	23.686"
24"	7.18"	27.125"	24"	27.750"
30"	7.18"	33.125"	30"	33.750"

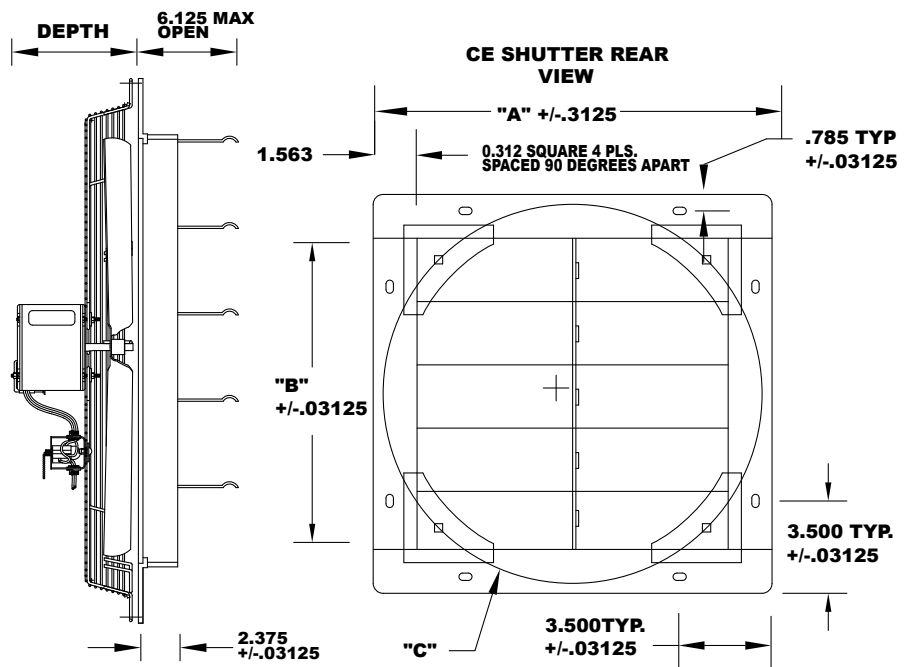



# Guard Mounted Direct Drive Exhaust Fans

## Features

- Bolts directly to the wall
- Can be used with or without external shutter
- Pull chain switch
- No Cord-Junction box provided for direct wiring
- Aluminum blade
- Steel spiral wire guards
- Made in U.S.A. with domestic and foreign components.

**WARNING:** This product can expose you to chemicals including nickel which is known to the State of California to cause cancer, and chromium, which is known to the State of California to cause birth defects and/or reproductive harm. For more information go to [www.P65Warnings.ca.gov](http://www.P65Warnings.ca.gov).

**Note:** Rough-in hole size is 1/2" inch larger than fan blade size



## Motor Specifications

- 120V, 1-Phase, totally enclosed, permanently lubricated
- 1/12 HP motor is 3-Speed sleeve bearing permanent split capacitor
- 1/8 HP motor is 3-Speed sleeve bearing permanent split capacitor
- 1/4 HP motor is 2-Speed ball bearing permanent split capacitor

## Standard Models

FAN SIZE	MFG CATALOG NUMBER	MFG MODEL NUMBER	HP	CFM / RPM			AMPS HIGH	WT. (LBS)
				HIGH	MED	LOW		
10"	08689502	CE 10-D	1/12	680 / 1560	540 / 1250	460 / 1080	1	11
12"	07985002	CE 12-D	1/12	825 / 1560	710 / 1250	560 / 1080	1.1	12
14"	08689602	CE 14-D	1/8	1520 / 1660	1400 / 1550	1250 / 1370	2	17
16"	08689702	CE 16-D	1/8	2100 / 1660	1900 / 1550	1700 / 1370	2.1	18
18"	07984902	CE 18-D	1/8	2300 / 1660	2100 / 1050	1850 / 1370	2.2	19
20"	08689802	CE 20-D	1/4	2925 / 1140	-	2380 / 1070	2.3	34
24"	07984802	CE 24-D	1/4	3400 / 1140	-	2770 / 1070	2.5	38
30"	07984702	CE 30-D	1/4	3950 / 1140	-	3080 / 1070	2.7	42

## Dimensions (Inches)

SIZE	BOLT HOLE CENTER WIDTH	DEPTH
10"	14.14"	5.81"
12"	16.46"	7.18"
14"	18.30"	7.18"
16"	20.34"	7.18"
18"	22.64"	7.18"
20"	25.46"	7.18"
24"	29.08"	7.18"
30"	34.89"	7.18"

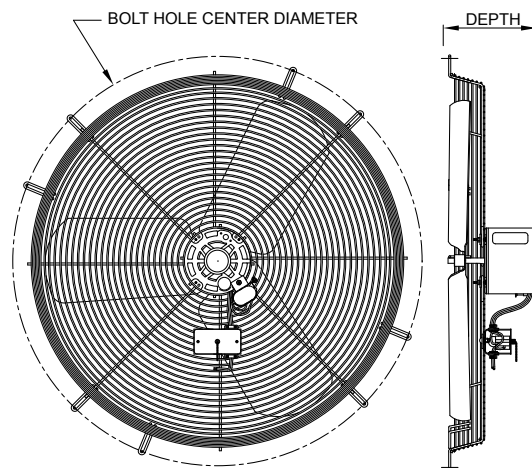

## Optional Wall Shutters

FAN SIZE	MFG CATALOG NUMBER	MFG MODEL NUMBER	WT. (LBS)
10"	08684302	CES-10G	5
12"	07985502	CES-12G	5.5
14"	08684502	CES-14G	6.5
16"	08514702	CES-16G	8
18"	07985602	CES-18G	9
20"	07975202	CES-20G	10
24"	07985702	CES-24G	13
30"	07985802	CES-30G	19

# Venturi Mounted Direct Drive Exhaust Fans

## Features

- Can be installed from inside wall
- Can be used with external shutter
- Pull chain switch
- No Cord-Junction box provided for direct wiring
- Aluminum blade
- Steel spiral wire guards
- Made in U.S.A. with domestic and foreign components



## Motor Specifications

- 120V, 1-Phase, totally enclosed, permanently lubricated
- 1/12 HP motor is 3-Speed sleeve bearing permanent split capacitor
- 1/8 HP motor is 3-Speed sleeve bearing permanent split capacitor
- 1/4 HP motor is 2-Speed ball bearing permanent split capacitor

**WARNING:** This product can expose you to chemicals including nickel which is known to the State of California to cause cancer, and chromium, which is known to the State of California to cause birth defects and/or reproductive harm. For more information go to [www.P65Warnings.ca.gov](http://www.P65Warnings.ca.gov).

**Note:** Rough-in hole size is 1/2" inch larger than fan blade size

## Standard Models

FAN SIZE	MFG CATALOG NUMBER	MFG MODEL NUMBER	HP	CFM / RPM			AMPS HIGH	WT. (LBS)
				HIGH	MED	LOW		
10"	08690302	CE 10-DV	1/12	680 / 1560	540 / 1250	460 / 1080	1	11
12"	07986602	CE 12-DV	1/12	825 / 1560	710 / 1250	560 / 1080	1.1	17
14"	08690402	CE 14-DV	1/8	1520 / 1660	1400 / 1550	1250 / 1370	2	17
16"	08690502	CE 16-DV	1/8	2100 / 1660	1900 / 1550	1700 / 1370	2.1	18
18"	07986702	CE 18-DV	1/8	2300 / 1660	2100 / 1050	1850 / 1370	2.2	26
20"	08690602	CE 20-DV	1/4	2925 / 1140	-	2380 / 1070	2.3	34
24"	07986802	CE 24-DV	1/4	3400 / 1140	-	2770 / 1070	2.5	48
30"	07986902	CE 30-DV	1/4	3950 / 1140	-	3080 / 1070	2.7	55

## Dimensions (Inches)

SIZE	DEPTH	DIMENSIONS				
		"A"	"B"	"C"	"D"	"E"
10"	5.81"	10.250"	12.63"	12.375"	2.000"	12.875"
12"	7.18"	12.250"	14.50"	14.375"	2.000"	14.625"
14"	7.18"	14.250"	17.13"	16.375"	2.500"	17.375"
16"	7.18"	16.250"	19.13"	18.250"	2.875"	20.000"
18"	7.18"	18.125"	21.00"	21.750"	2.750"	22.875"
20"	7.18"	20.250"	23.13"	23.686"	2.750"	25.625"
24"	7.18"	24.250"	29.50"	27.750"	2.875"	27.875"
30"	7.18"	30.250"	33.50"	33.750"	2.875"	33.875"

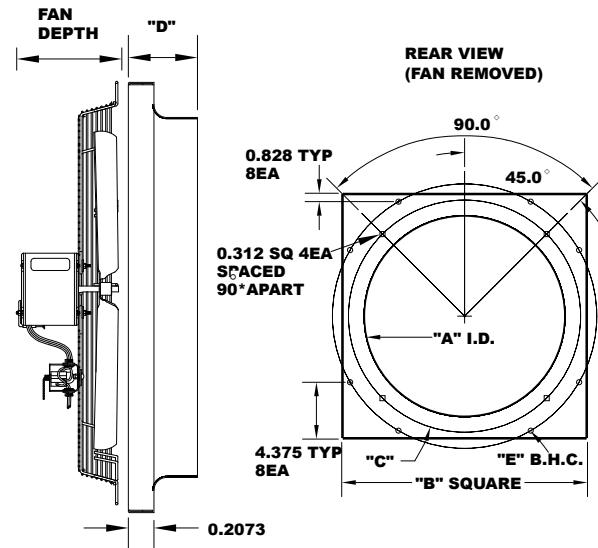

## Optional Wall Shutters

FAN SIZE	MFG CATALOG NUMBER	MFG MODEL NUMBER	DIMENSIONS		WT. (LBS)
			WIDTH	LENGTH	
10"	08684302	CES-10G	13.13"	13.13"	5.0
12"	07985502	CES-12G	15.13"	15.13"	5.5
14"	08684502	CES-14G	17.13"	17.13"	6.5
16"	08514702	CES-16G	19.00"	19.00"	8.0
18"	07985602	CES-18G	21.13"	21.13"	9.0
20"	07975202	CES-20G	23.13"	23.13"	10.0
24"	07985702	CES-24G	27.13"	27.13"	13.0
30"	07985802	CES-30G	33.13"	33.13"	19.0

# Belt Drive Exhaust Fans & Optional Shutters

## Venturi Mounted Belt Drive Exhaust Fan

### Features

- Steel venturi frame exhaust fan, bolts directly to an inside wall or framed / vertical surface
- Motor is designed for direct wiring connection; NO cord provided
- Operates at 115/120V at single-phase or 230/460V at 3-phase; 1725 RPMs
- Single speed, belt drive motor constructed of ball bearing, split capacitor, drip proof and is permanently lubricated
- Steel frame has a gray powder coated finish and uses a 4-paddle aluminum blade
- Designed for harsh industrial and commercial environments to improve air quality
- Belt drive motor allows for quieter operation and higher air volume performance
- Can be used with or without external shutter (sold separately)
- UL recognized motor has a frame size of 56
- Proudly Designed, Engineered, Tested and Assembled in the USA



### Dimensions (Inches)

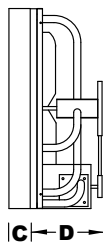
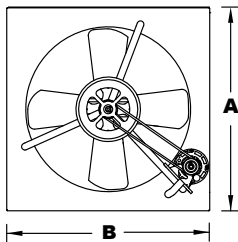

MODEL	DIMENSIONS A x B x C x D
CE-24B	29.5" x 31" x .75" x 17"
CE-30B	35.5" x 34" x .75" x 17"
CE-36B	41.5" x 40" x .75" x 17"
CE-42B	48" x 48" x .75" x 17"
CE-48B	54" x 54" x .75" x 17"

**WARNING:** This product can expose you to chemicals including nickel which is known to the State of California to cause cancer, and chromium, which is known to the State of California to cause birth defects and/or reproductive harm. For more information go to [www.P65Warnings.ca.gov](http://www.P65Warnings.ca.gov).

### Standard Models

SIZE	MOTOR HP	AMPS		CFM	WT. (LBS)	115V 1-PHASE		230/460V 3-PHASE	
		115V	230/460V			MFG CATALOG NUMBER	MFG MODEL NUMBER	MFG CATALOG NUMBER	MFG MODEL NUMBER
24	1/3	5	1.9 / .9	10,000	50	07967002	CE-24B	08510402	CE-24B-3
30	1/3	6	1.9 / .9	11,600	60	07967102	CE-30B	08510502	CE-30B-3
36	1/2	8	2.3 / 1.1	14,000	65	07967202	CE-36B	08510602	CE-36B-3
42	3/4	11	3.3 / 1.5	17,500	75	07967302	CE-42B	08510702	CE-42-B-3
48	1	15	3.8 / 1.9	23,500	98	07967402	CE-48B	08510802	CE-48-B-3

### Optional Exhaust Shutters



#### Features

- Air open - gravity close
- Aluminum frame
- Aluminum louvers
- Weather stripping for tighter seal
- For ONLY CE-Series BELT Drive Fans
- Made in U.S.A.

#### Standard Models

MFG CATALOG NUMBER	MFG MODEL NUMBER	WT. (LBS)
07967502	CES-24	11
07967602	CES-30	15
07967702	CES-36	19
07967802	CES-42	23
07967902	CES-48	28

### Shutter Dimensions (Inches)

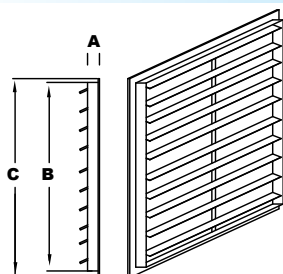

- (A) Thickness
- (B) Blade Housing Size
- (C) Overall Size

MFG MODEL NUMBER	OUTSIDE FRAME DIMENSIONS A x C x C	INSIDE FRAME DIMENSIONS B x B
CES-24	3" x 27" x 27"	24" x 24"
CES-30	3" x 33" x 33"	30" x 30"
CES-36	3" x 39" x 39"	36" x 36"
CES-42	3" x 45" x 45"	42" x 42"
CES-48	3" x 51" x 51"	48" x 48"

\* Recommend adding 1/2" to inside frame dimension for wall opening

# Industrial Direct Drive Exhaust Fans

## Features

- Totally enclosed motors:
  - 1-Phase motors are field convertible 115V / 230V
  - 3-Phase motors are field convertible 230V / 460V
  - Motors are set to lower voltage at the factory, unless a request is made at time of order to set to the higher voltage
- 14 gauge steel venturi with steel pipe bracing
- 4-blade steel propeller
- 1 year limited warranty



## Options

- CES Shutters
- EMF Front Guards
- IBG Rear Guards

**⚠ WARNING:** This product can expose you to chemicals including nickel which is known to the State of California to cause cancer, and chromium, which is known to the State of California to cause birth defects and/or reproductive harm. For more information go to [www.P65Warnings.ca.gov](http://www.P65Warnings.ca.gov).

## Standard Models

BLADE SIZE	MFG MODEL NUMBER		PANEL SIZE (Sq.)	HP	RPM	CFM 0" SP	db's @ 10'	WT. (LBS)
	1-PHASE	3-PHASE						
	115/230V-60Hz	208/230/460v-60Hz						
12"	IED12-1/4	IED12-1/4-3	16"	1/4	1725	1480	64	30
16"	IED16-1/3	IED16-1/3-3	20"	1/3	1725	2834	73	40
18"	IED18-1/2	IED18-1/2-3	24"	1/2	1725	3890	74	55
20"	IED20-3/4	IED20-3/4-3	24"	3/4	1725	4574	77	65
24"	IED24-1	IED24-1-3	30"	1	1725	6632	81	155
30"	IED30-1	IED30-1-3	36"	1	1150	8600	79	185
36"	IED36-1 1/2	IED36-1 1/2-3	42"	1.5	1150	12103	82	260
42"	-----	IED42-2-3	48"	2	1150	17315	87	280
48"	-----	IED48-3-3	54"	3	850	24280	86	360

**Note: Products listed in this section are custom built and subject to 100% cancellation/restocking charges**

## Dimensions

SIZE	BLADE DIAMETER	PANEL SIZE	DEPTH DIMENSION
12"	12"	16"	11"
16"	16"	20"	11"
20"	20"	24"	13"
24"	24"	30"	15"
30"	30"	36"	15"
36"	36"	42"	18"
42"	42"	48"	18"
48"	48"	54"	20"

**Note: Depth dimension varies with motor selection**

# Industrial Belt Drive Exhaust Fans

## Features

- Totally enclosed motors:
  - 1-Phase motors are field convertible 115V / 230V
  - 3-Phase motors are field convertible 230V / 460V
  - Motors are set to lower voltage at the factory, unless a request is made at time of order to set to the higher voltage
- 16 gauge steel venturi with steel pipe bracing
- Steel blades
- Double pillow block bearing shaft support
- 1 year limited warranty



**⚠ WARNING:** This product can expose you to chemicals including nickel which is known to the State of California to cause cancer, and chromium, which is known to the State of California to cause birth defects and/or reproductive harm. For more information go to [www.P65Warnings.ca.gov](http://www.P65Warnings.ca.gov).

## Options

- CES Shutters
- EMF Front Guard
- IBG Rear Guards

## Standard Models

BLADE SIZE	MFG MODEL NUMBER		PANEL SIZE (Sq.)	HP	RPM	CFM	db's @ 10'	WT. (LBS)
	1-PHASE	3-PHASE						
	115/230V-60Hz	208/230/460v-60Hz						
24"	IE24-1/3	IE24-1/3-3	30"	1/3	825	5300	61	70
	IE24-1/2	IE24-1/2-3		1/2	925	6200	66	75
	IE24-3/4	IE24-3/4-3		3/4	1050	7000	71	82
	IE24-1	IE24-1-3		1	1175	7800	73	90
30"	IE30-1/3	IE30-1/3-3	36"	1/3	570	7500	62	95
	IE30-1/2	IE30-1/2-3		1/2	625	8500	64	95
	IE30-3/4	IE30-3/4-3		3/4	725	10000	66	105
	IE30-1	IE30-1-3		1	825	11000	70	115
36"	IE36-1/3	IE36-1/3-3	42"	1/3	425	9000	64	103
	IE36-1/2	IE36-1/2-3		1/2	500	10500	66	105
	IE36-3/4	IE36-3/4-3		3/4	575	11900	68	110
	IE36-1	IE36-1-3		1	650	13100	70	120
	IE36-1 1/2	IE36-1 1/2-3		1 1/2	750	15000	72	155
	IE36-2	IE36-2-3		2	830	16500	74	165
42"	IE42-3/4	IE42-3/4-3	48"	3/4	430	14000	67	175
	IE42-1	IE42-1-3		1	490	15400	69	180
	IE42-1 1/2	IE42-1 1/2-3		1 1/2	550	17200	71	185
	IE42-2	IE42-2-3		2	620	19400	74	200
	-----	IE42-3-3		3	700	22000	79	225
48"	IE48-3/4	IE48-3/4-3	54"	3/4	350	17000	70	185
	IE48-1	IE48-1-3		1	400	19100	71	190
	IE48-1 1/2	IE48-1 1/2-3		1 1/2	460	22000	72	200
	IE48-2	IE48-2-3		2	520	24000	74	250
	-----	IE48-3-3		3	590	27500	80	260
	-----	IE48-5-3		5	660	30500	83	280
60"	IE60-2	IE60-2-3	66"	2	320	31000	77	320
	-----	IE60-3-3		3	370	35000	84	330
	-----	IE60-5-3		5	420	39000	86	350

**Note: Products listed in this section are custom built and subject to 100% cancellation/restocking charges**

## Dimensions

SIZE	BLADE DIAMETER	PANEL SIZE	DEPTH DIMENSION
24"	24"	30"	18"
30"	30"	36"	18"
36"	36"	42"	20"
42"	42"	48"	20"
48"	48"	54"	22"
60"	60"	66"	28"

**Note: Depth dimension varies with motor selection**

# Heavy Duty Direct Drive Exhaust Fans

## Features

- Totally enclosed and explosion proof motors
  - Explosion proof motors are Class 1, Div 1 Group D and Class 2, Div 1, Groups F & G
- Fans are shipped completely assembled
- Cast aluminum blades
- 14 gauge steel panel with welded steel pipe bracing
- 1 year limited warranty

**⚠ WARNING:** This product can expose you to chemicals including nickel which is known to the State of California to cause cancer, and chromium, which is known to the State of California to cause birth defects and/or reproductive harm. For more information go to [www.P65Warnings.ca.gov](http://www.P65Warnings.ca.gov).



## Options

- CES Shutters
- EMF Front Guards
- IBG Rear Guards
- Acid Resistant Coating
- Reversed Air Flow
- Flat Front Venturi

## Standard Models

BLADE SIZE	MFG MODEL NUMBER		PANEL SIZE (Sq.)	HP	RPM	CFM 0" SP	db's @ 10'	WT. (LBS)
	1-PHASE 115/230V-60Hz	3-PHASE 208/230/460v-60Hz						
12"	EHD12-1/4	EHD12-1/4-3	16"	1/4	1725	1180	74	35
16"	EHD16-1/4	EHD16-1/4-3	20"	1/4	1725	2800	75	45
18"	EHD18-1/3	EHD18-1/3-3	24"	1/3	1725	3375	75	60
	EHD18-1/2	EHD18-1/2-3		1/2	1725	4150	76	60
20"	EHD20-1/4	EHD20-1/4-3	24"	1/4	1725	3720	75	60
	EHD20-1/2	EHD20-1/2-3		1/2	1725	4800	76	65
	EHD20-1	EHD20-1-3		1	1725	6900	77	70
24"	EHD24-1/4	EHD24-1/4-3	30"	1/4	1725	5200	82	135
	EHD24-1/3	EHD24-1/3-3		1/3	1150	4975	75	145
	EHD24-1/2	EHD24-1/2-3		1/2	1725	6510	82	140
	EHD24-3/4	EHD24-3/4-3		3/4	1725	6900	83	145
	EHD24-1	EHD24-1-3		1	1725	7425	83	155
	EHD24-2	EHD24-2-3		2	1725	9525	83	165
30"	-----	EHD24-3-3	36"	3	1725	10500	85	170
	EHD30-1/3	EHD30-1/3-3		1/3	1150	6950	79	145
	EHD30-1/2	EHD30-1/2-3		1/2	1725	8980	89	135
	EHD30-3/4	EHD30-3/4-3		3/4	1150	10440	79	175
	-----	EHD30-1-3		1	870	10640	74	215
	EHD30-1 1/2	EHD30-1 1/2-3		1 1/2	1725	12000	89	165
	EHD30-2	EHD30-2-3		2	1150	14000	82	215
36"	-----	EHD30-3-3	42"	3	1725	16000	89	190
	EHD36-1	EHD36-1-3		1	1150	13600	84	225
	-----	EHD36-2-3		2	1150	17620	84	250
	-----	EHD36-3-3		3	1150	20500	85	255
	-----	EHD36-5-3		5	1725	28000	94	250
42"	-----	EHD42-1-3	48"	1	870	15800	82	300
	EHD42-2	EHD42-2-3		2	1150	17964	88	260
	-----	EHD42-3-3		3	1150	24500	88	270
	-----	EHD42-5-3		5	1150	28970	88	285
48"	-----	EHD48-3-3	54"	3	1150	28600	92	290
	-----	EHD48-5-3		5	1150	32000	94	305
60"	-----	EHD60-3-3	66"	3	1150	40000	97	700
	-----	EHD60-5-3		5	1150	45000	97	730
	-----	EHD60-7 1/2-3		7 1/2	870	47000	92	740
	-----	EHD60-10-3		10	870	57200	93	750

Single Phase motors are field convertible 115V/230V. Three phase motors are field convertible 230V/460V. Motors are set to lower voltage at the factory, unless a request is made at time of order to set to the higher voltage.

**Note: Products listed in this section are custom built and subject to 100% cancellation/restocking charges**

\*Not all EXP motors are 208V capable

## Dimensions

SIZE	BLADE DIAMETER	PANEL SIZE	DEPTH DIMENSION
12"	12"	16"	11"
16"	16"	20"	11"
20"	20"	24"	13"
24"	24"	30"	15"
30"	30"	36"	15"
36"	36"	42"	18"
42"	42"	48"	18"
48"	48"	54"	20"
60"	60"	66"	22"

**Note: Depth dimension varies with motor selection**

# Heavy Duty Belt Drive Exhaust Fans

## Features

- Totally enclosed and explosion proof motors
  - Explosion proof motors are Class 1, Div 1 Group D and Class 2, Div 1, Groups F & G
- Fans are shipped completely assembled
- Heavy gauge steel blades on TEC models
- Cast aluminum blades on EXP explosion proof models
- 14 gauge steel panel with welded steel pipe bracing
- 1 year limited warranty
- For optimum shutter efficiency, mount shutter  $\frac{1}{3}$  the distance of the fan opening size.  
Example: 36" fan shutter would be mounted 12" from the fan blade

**⚠ WARNING:** This product can expose you to chemicals including nickel which is known to the State of California to cause cancer, and chromium, which is known to the State of California to cause birth defects and/or reproductive harm. For more information go to [www.P65Warnings.ca.gov](http://www.P65Warnings.ca.gov).

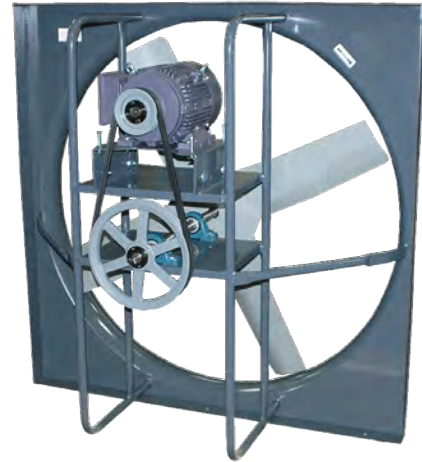

## Options

- CES Shutters
- Reversed Air Flow
- EMF Front Guards
- Flat Front Venturi
- IBG Rear Guards

## Standard Models

BLADE SIZE	MFG MODEL NUMBER		PANEL SIZE (Sq.)	HP	RPM	CFM 0" SP	db's @ 10"	WT. (LBS)
	1-PHASE	3-PHASE						
	115/230V-60Hz	208/230/460v-60Hz						
24"	EHB24-1/4	EHB24-1/4-3	30"	1/4	780	4900	60	100
	EHB24-1/2	EHB24-1/2-3		1/2	980	6219	66	130
	EHB24-3/4	EHB24-3/4-3		3/4	1140	7090	71	140
	EHB24-1	EHB24-1-3		1	1250	7180	73	140
30"	EHB30-1/4	EHB30-1/4-3	36"	1/4	540	7178	61	140
	EHB30-1/3	EHB30-1/3-3		1/3	595	7909	63	150
	EHB30-1/2	EHB30-1/2-3		1/2	640	8507	64	155
	EHB30-3/4	EHB30-3/4-3		3/4	770	10235	66	165
	EHB30-1	EHB30-1-3		1	975	10668	70	170
	EHB30-1 1/2	EHB30-1 1/2-3		1 1/2	1140	12473	77	180
36"	EHB36-1/3	EHB36-1/3-3	42"	1/3	460	9113	64	160
	EHB36-1/2	EHB36-1/2-3		1/2	530	10500	66	180
	EHB36-3/4	EHB36-3/4-3		3/4	605	11985	68	200
	EHB36-1	EHB36-1-3		1	665	13174	70	200
	EHB36-1 1/2	EHB36-1 1/2-3		1 1/2	720	13660	72	210
	EHB36-2	EHB36-2-3		2	870	16554	74	215
42"	EHB42-1/3	EHB42-1/3-3	48"	1/3	335	10614	64	205
	EHB42-1/2	EHB42-1/2-3		1/2	390	12343	65	210
	EHB42-3/4	EHB42-3/4-3		3/4	435	14040	67	225
	EHB42-1	EHB42-1-3		1	490	15429	69	230
	EHB42-1 1/2	EHB42-1 1/2-3		1 1/2	550	17420	71	240
	EHB42-2	EHB42-2-3		2	725	20653	74	245
	----	EHB42-3-3		3	830	23645	79	250
	EHB48-1/2	EHB48-1/2-3		54"	1/2	330	15230	69
EHB48-3/4	EHB48-3/4-3	3/4	370		17339	70	195	
EHB48-1	EHB48-1-3	1	410		19188	71	235	
EHB48-1 1/2	EHB48-1 1/2-3	1 1/2	465		21731	72	245	
EHB48-2	EHB48-2-3	2	520		24274	74	250	
----	EHB48-3-3	3	680		28150	80	270	
----	EHB48-5-3	5	800		33160	83	285	
EHB60-1	EHB60-1-3	66"	1		280	23090	76	380
EHB60-1 1/2	EHB60-1 1/2-3		1 1/2	340	28068	77	390	
EHB60-2	EHB60-2-3		2	390	32200	78	395	
----	EHB60-3-3		3	450	37183	84	410	
----	EHB60-5-3		5	540	44600	86	420	

Single Phase motors are field convertible 115V/230V. Three phase motors are field convertible 230V/460V.

Motors are set to lower voltage at the factory, unless a request is made at time of order to set to the higher voltage.

**Note: Products listed in this section are custom built and subject to 100% cancellation/restocking charges.**

\*Not all EXP motors are 208V capable.

## Dimensions

SIZE	BLADE DIAMETER	PANEL SIZE	DEPTH DIMENSION
24"	24"	30"	16"
30"	30"	36"	16"
36"	36"	42"	18"
42"	42"	48"	20"
48"	48"	54"	21"
60"	60"	66"	26"

**Note: Depth dimension varies with motor selection.**

# Cabinet Exhaust Fans With Shutters

## Features

- 120V, 1-Phase or 230 / 460V, 3-Phase, ball bearing, permanently lubricated, drip proof motor - UL listed
- Permanently lubricated bearings on blade drive shaft
- Aluminum blade
- Aluminum shutter
- 20 gauge powder coated venturi
- 18 gauge galvanized steel housing
- 1725 RPM motor
- Motor frame size 56 / Shaft:  $\frac{5}{8}$ "
- Ships fully assembled
- Meets OSHA Standards
- 1 year warranty
- Made in U.S.A.

**WARNING:** This product can expose you to chemicals including nickel which is known to the State of California to cause cancer, and chromium, which is known to the State of California to cause birth defects and/or reproductive harm. For more information go to [www.P65Warnings.ca.gov](http://www.P65Warnings.ca.gov).



## Standard Models

SIZE	MOTOR HP	AMPS		CFM	WT. (LBS)	115V 1-PHASE		230 / 460V 3-PHASE	
		115V	230/460V			MFG CATALOG NUMBER	MFG MODEL NUMBER	MFG CATALOG NUMBER	MFG MODEL NUMBER
30	1/3	6	1.9 / .9	11,600	120	08684002	CBT-30B	08685302	CBT-30B-3
36	1/2	8	2.3 / 1.1	14,000	135	08684102	CBT-36B	08685402	CBT-36B-3
42	3/4	11	3.3 / 1.5	17,500	155	08684202	CBT-42B	08685502	CBT-42B-3
48	1	15	3.8 / 1.9	23,500	200	08685102	CBT-48B	08685002	CBT-48B-3

## Dimensions

SIZE	OUTSIDE DIMENSIONS			MAXIMUM REQUIRED INSIDE WALL OPENING
	HEIGHT	WIDTH	DEPTH	
24"	28 $\frac{1}{4}$ "	28 $\frac{1}{4}$ "	22 $\frac{1}{2}$ "	28 $\frac{3}{4}$ " x 28 $\frac{3}{4}$ "
30"	34 $\frac{1}{4}$ "	34 $\frac{1}{4}$ "	22 $\frac{1}{2}$ "	34 $\frac{1}{2}$ " x 34 $\frac{1}{2}$ "
36"	40 $\frac{1}{4}$ "	40 $\frac{1}{4}$ "	18 $\frac{1}{2}$ "	40 $\frac{1}{2}$ " x 40 $\frac{1}{2}$ "
42"	48 $\frac{1}{2}$ "	48 $\frac{1}{2}$ "	18 $\frac{1}{2}$ "	48 $\frac{3}{4}$ " x 48 $\frac{3}{4}$ "
48"	54 $\frac{1}{2}$ "	54 $\frac{1}{2}$ "	21 $\frac{1}{2}$ "	54 $\frac{3}{4}$ " x 54 $\frac{3}{4}$ "



# Exhaust Fan Accessories - Heavy Duty Exhaust Shutter

## Features

- Air open - Gravity close
- Aluminum construction
- Heavy duty blades
- Weather stripping for tighter seal
- For optimum shutter efficiency, mount shutter  $\frac{1}{3}$  the distance of the fan opening size. Example: 36" fan shutter would be mounted 12" from the fan blade
- Shutter should be sized to fit exhaust opening
- For IE, IED, EHB and EHD models



**WARNING:** This product can expose you to chemicals including nickel which is known to the State of California to cause cancer, and chromium, which is known to the State of California to cause birth defects and/or reproductive harm. For more information go to [www.P65Warnings.ca.gov](http://www.P65Warnings.ca.gov).

## Standard Models

FAN SIZE	MFG CATALOG NUMBER	MFG MODEL NUMBER	INSIDE FRAME DIMENSIONS	OUTSIDE FRAME DIMENSIONS	WT. (LBS)
12"	07983302	CES 12-HD	12" x 12"	14" x 15"	4
16"	08709102	CES 16-HD	16" x 16"	19" x 19"	7
18"	08518902	CES 18-HD	18" x 18"	21" x 21"	8
20"	08696602	CES 20-HD	20" x 20"	23" x 23"	9
24"	08757202	CES 24-HD	24" x 24"	27" x 27"	11
30"	08757302	CES 30-HD	30" x 30"	33" x 33"	15
36"	08757402	CES 36-HD	36" x 36"	39" x 39"	19
42"	08757502	CES 42-HD	42" x 42"	45" x 45"	23
48"	08757602	CES 48-HD	48" x 48"	51" x 51"	28
54"	08775102	CES 54-HD	54" x 54"	57" x 57"	39
60"	07998702	CES 60-HD	60" x 60"	63" x 63"	47

## Heavy Duty Shutter Motor Kit Features



- Used to open shutter when shutter is used to provide make-up air (Shutter should be one size larger than exhaust fan size and should be located on opposite wall)
- Used for positive closure of exhaust shutter
- 115V or 230V, 60 HZ, 1-Phase

## Standard Models

MFG CATALOG NUMBER	MFG MODEL NUMBER	DESCRIPTION	WT. (LBS)
07971002	MK-1	For shutter sizes 12" thru 30" (Single Panel)	5
07971102	MK-2	For shutter sizes 36" thru 60" (Double Panel)	8

## Motorized Supply Air Intake Shutter

### Features

- Inward opening blades for use with intake fans when shutter is located directly in air stream
- Galvanized construction
- 115V or 230V, 60 HZ, 1-Phase
- For IE, IED, EHB and EHD models

### Standard Models

FAN SIZE	MFG CATALOG NUMBER	MFG MODEL NUMBER	ROUGH OPENING	OVERALL SIZE	WT. (LBS)
24"	08516902	CESM-24	24" x 24"	27" x 27"	15
30"	08007102	CESM-30	30" x 30"	33" x 33"	18
36"	08004602	CESM-36	36" x 36"	39" x 39"	21
42"	08517202	CESM-42	42" x 42"	45" x 45"	35
48"	07997202	CESM-48	48" x 48"	51" x 51"	42
60"	07983002	CESM-60	60" x 60"	63" x 63"	56



**WARNING:** This product can expose you to chemicals including nickel which is known to the State of California to cause cancer, and chromium, which is known to the State of California to cause birth defects and/or reproductive harm. For more information go to [www.P65Warnings.ca.gov](http://www.P65Warnings.ca.gov).

## Rear Box Guard Bolt Together With Wire Guards



**WARNING:** This product can expose you to chemicals including nickel which is known to the State of California to cause cancer, and chromium, which is known to the State of California to cause birth defects and/or reproductive harm. For more information go to [www.P65Warnings.ca.gov](http://www.P65Warnings.ca.gov).

### Features

- For IE, IED, EHB and EHD models
- ¼" Smaller than the panel size of the fan
- Meets OSHA requirements

### Standard Models

MFG MODEL NUMBER	FITS FAN SIZE
IBG-24	24"
IBG-30	30"
IBG-36	36"
IBG-42	42"
IBG-48	48"
IBG-60	60"

## Rear Expanded Metal Box Guard



**WARNING:** This product can expose you to chemicals including nickel which is known to the State of California to cause cancer, and chromium, which is known to the State of California to cause birth defects and/or reproductive harm. For more information go to [www.P65Warnings.ca.gov](http://www.P65Warnings.ca.gov).

### Features

- For IE, IED, EHB and EHD models
- ¼" Smaller than the panel size of the fan
- Meets OSHA requirements

### Standard Models

MFG MODEL NUMBER	FITS FAN SIZE
IBG-12	12"
IBG-16	16"
IBG-18	18"
IBG-20	20"

## Spiral Front and Rear Guards

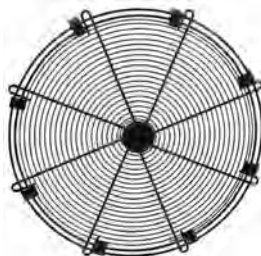

Spiral Front

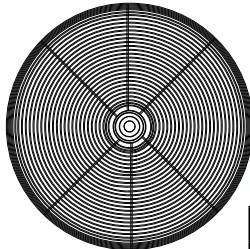

Spiral Rear

**WARNING:** This product can expose you to chemicals including nickel which is known to the State of California to cause cancer, and chromium, which is known to the State of California to cause birth defects and/or reproductive harm. For more information go to [www.P65Warnings.ca.gov](http://www.P65Warnings.ca.gov).

### Features

- For EHD models only
- Fits between motor and blade
- Rear guard installed at factory only
- Meets OSHA requirements

### Standard Models

MFG MODEL NUMBER	TYPE	FITS FAN SIZE
SF-12	SPIRAL FRONT	12"
SF-16		16"
SF-18		18"
SF-20		20"
SF-24		24"
SR-12	SPIRAL REAR	12"
SR-16		16"
SR-18		18"
SR-20		20"
SR-24		24"

## Expanded Metal Front Guard

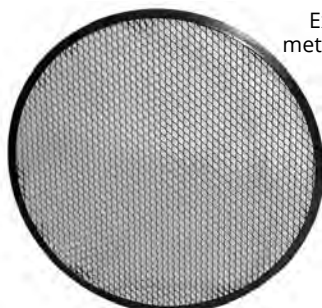

Expanded metal guard 60"

**WARNING:** This product can expose you to chemicals including nickel which is known to the State of California to cause cancer, and chromium, which is known to the State of California to cause birth defects and/or reproductive harm. For more information go to [www.P65Warnings.ca.gov](http://www.P65Warnings.ca.gov).

### Features

- For EHB, EHD, IE, & IED models
- 1" Larger than blade size
- Meets OSHA requirements

### Standard Models

MFG MODEL NUMBER	FITS FAN SIZE
EMF-12	12"
EMF-16	16"
EMF-20	20"
EMF-24	24"
EMF-30	30"
EMF-36	36"
EMF-42	42"
EMF-48	48"
EMF-60	60"

# Cabinet Exhaust Fan Package Option

## With Bolt Together Rear Guard

### Package Includes

- Wall collar
- Automatic shutter
- Rear box guard

### Features

- For IE, IED, EHB and EHD models
- Wall collar OD is ¼" larger than fan panel size
- Meets OSHA requirements

### Standard Models

MFG MODEL NUMBER	FAN SIZE
CEFP-24	24"
CEFP-30	30"
CEFP-36	36"
CEFP-42	42"
CEFP-48	48"



**⚠ WARNING:** This product can expose you to chemicals including nickel which is known to the State of California to cause cancer, and chromium, which is known to the State of California to cause birth defects and/or reproductive harm. For more information go to [www.P65Warnings.ca.gov](http://www.P65Warnings.ca.gov).

## With Expanded Metal Rear Guard

### Package Includes

- Wall collar
- Automatic shutter
- Rear box guard

### Features

- For IE, IED, EHB and EHD models
- Wall collar OD is ¼" larger than fan panel size
- Meets OSHA requirements

### Standard Models

MFG MODEL NUMBER	FAN SIZE
CEFP-12	12"
CEFP-16	16"
CEFP-18	18"
CEFP-20	20"
CEFP-60	60"



**⚠ WARNING:** This product can expose you to chemicals including nickel which is known to the State of California to cause cancer, and chromium, which is known to the State of California to cause birth defects and/or reproductive harm. For more information go to [www.P65Warnings.ca.gov](http://www.P65Warnings.ca.gov).

# Exterior Weather Hood Option

### Features

- For IE, IED, EHB and EHD models.
- Galvanized housing with ½ - 16 expanded metal bird screen
- Can be used for intake or exhaust
- Meets OSHA requirements

### Standard Models

MFG MODEL NUMBER	FAN SIZE
WH-12	12"
WH-16	16"
WH-18	18"
WH-20	20"
WH-24	24"
WH-30	30"
WH-36	36"
WH-42	42"
WH-48	48"
WH-60	60"

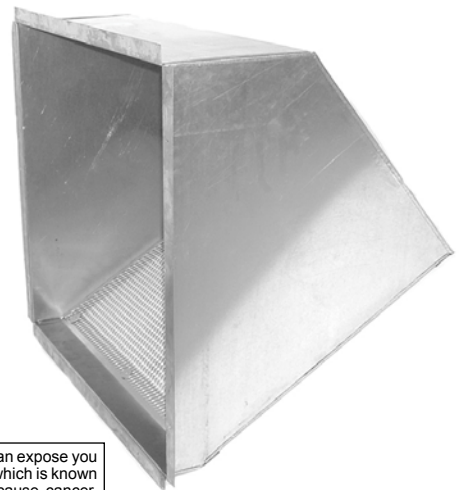

**⚠ WARNING:** This product can expose you to chemicals including nickel which is known to the State of California to cause cancer, and chromium, which is known to the State of California to cause birth defects and/or reproductive harm. For more information go to [www.P65Warnings.ca.gov](http://www.P65Warnings.ca.gov).

# Insulated Roof Curbs

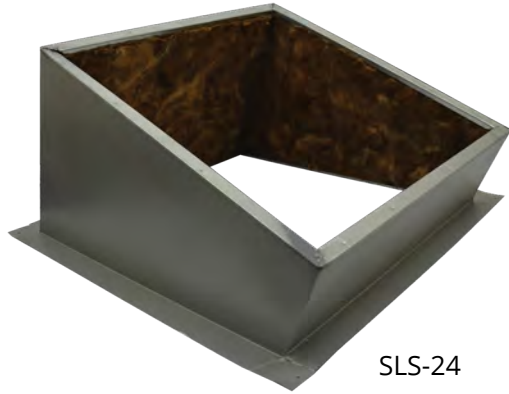

SLS-24

## Features

- Used with UEB, UED, and RE roof ventilators
- For flat, single slope or ridge style roofs
- Galvanized steel construction
- 1-½" insulated thickness, 3 pounds density
- 8" height overall
- Not for corrugated roofs

**⚠ WARNING:** This product can expose you to chemicals including nickel which is known to the State of California to cause cancer, and chromium, which is known to the State of California to cause birth defects and/or reproductive harm. For more information go to [www.P65Warnings.ca.gov](http://www.P65Warnings.ca.gov).

## Standard Models

FAN	MFG MODEL NUMBER			BASE DIMENSION	OVERALL DIMENSION
	FLAT	SLOPE	RIDGE		
18"	FLS-18	SLS-18	RDS-18	32" x 32"	44" x 44"
24"	FLS-24	SLS-24	RDS-24	38" x 38"	50" x 50"
30"	FLS-30	SLS-30	RDS-30	44" x 44"	56" x 56"
36"	FLS-36	SLS-36	RDS-36	50" x 50"	62" x 62"
42"	FLS-42	SLS-42	RDS-42	56" x 56"	68" x 68"
48"	FLS-48	SLS-48	RDS-48	62" x 62"	74" x 74"
54"	FLS-54	SLS-54	RDS-54	68" x 68"	80" x 80"
60"	FLS-60	SLS-60	RDS-60	74" x 74"	86" x 86"

## Back Draft Dampers to Fit in Curb

UEB and UED models require higher curb height when used with back draft damper; consult factory

FAN SIZE	MFG MODEL NUMBER	SHUTTER SIZE
18"	CD-18	28" x 28"
24"	CD-24	34" x 34"
30"	CD-30	40" x 40"
36"	CD-36	46" x 46"
42"	CD-42	52" x 52"
48"	CD-48	58" x 58"
54"	CD-54	64" x 64"
60"	CD-60	70" x 70"

## Motor Kit for Dampers

115V or 230V, 60Hz, 1-Phase. (Specify Voltage)

MFG MODEL NUMBER	DESCRIPTION	WT. (LBS)
DMKP1	For shutter sizes 18" thru 36"	5
DMKP2	For shutter sizes 42" thru 60"	8

# Belt Drive Hooded Roof Ventilators



CLOSED

**WARNING:** This product can expose you to chemicals including nickel which is known to the State of California to cause cancer, and chromium, which is known to the State of California to cause birth defects and/or reproductive harm. For more information go to [www.P65Warnings.ca.gov](http://www.P65Warnings.ca.gov).



OPEN

## Features

- Used for exhaust or intake
- Heavy industrial steel base with aluminum hood
- Steel blades
- Bird screen included
- No back draft protection in standard construction dampers offered as optional accessory
- 1 year limited warranty

## Options

- Direct drive
- Protective coatings
- Roof curb
- Filters

## Dimensions

SIZE	MINIMUM ROOF HOLE (SQUARE)	HOLE LENGTH x WIDTH	HOOD HEIGHT	ROOF CURB O.D. (SQUARE)
24"	30"	54" x 64"	30"	39"
30"	36"	60" x 76"	36"	45"
36"	42"	72" x 82"	40"	51"
42"	48"	80" x 89"	43"	57"
48"	54"	87" x 95"	46"	63"
54"	60"	92" x 98"	54"	69"
60"	66"	90" x 107"	56"	75"

## Standard Models

BLADE SIZE	1-PHASE 115/230V	3-PHASE 208/230/460v	HP	RPM	C.F.M - STATIC PRESSURE				Db's @ 10'	WT. (LBS)
	MFG MODEL NUMBER				0"	1/8"	1/4"	1/2"		
24"	RE24-1/4	RE24-1/4-3	1/4	780	4900	4222	2807	800	60	340
	RE24-1/2	RE24-1/2-3	1/2	980	6219	5716	5061	2600	66	350
	RE24-3/4	RE24-3/4-3	3/4	1140	7090	6648	6144	4413	71	360
	RE24-1	RE24-1-3	1	1250	7180	6696	6271	4464	73	365
30"	RE30-1/3	RE30-1/3-3	1/3	595	7909	6380	3617	767	60	385
	RE30-1/2	RE30-1/2-3	1/2	640	8507	7170	4486	1373	64	385
	RE30-3/4	RE30-3/4-3	3/4	770	10235	9192	7657	3833	66	400
	RE30-1	RE30-1-3	1	975	10668	9959	8626	5184	70	400
36"	RE30-1 1/2	RE30-1 1/2-3	1.5	1140	12473	11867	11112	8135	77	410
	RE36-1/3	RE36-1/3-3	1/3	460	9113	6992	3722	486	64	425
	RE36-1/2	RE36-1/2-3	1/2	530	10500	8821	5985	2084	66	425
	RE36-3/4	RE36-3/4-3	3/4	605	11985	10583	8563	4017	68	435
	RE36-1	RE36-1-3	1	665	13174	11932	10299	5729	70	440
42"	RE36-1 1/2	RE36-1 1/2-3	1.5	720	13660	12012	9579	5000	72	440
	RE36-2	RE36-2-3	2	870	16554	15376	14088	9691	74	455
	RE42-1/2	RE42-1/2-3	1/2	390	12343	9352	4957	1642	65	540
	RE42-3/4	RE42-3/4-3	3/4	435	14040	11530	7633	3311	67	545
	RE42-1	RE42-1-3	1	490	15429	13194	10438	4668	69	555
48"	RE42-1 1/2	RE42-1 1/2-3	1.5	550	17420	15421	13117	7289	71	560
	RE42-2	RE42-2-3	2	725	20653	19128	17503	11319	74	570
	-----	RE42-3-3	3	830	23645	22296	20984	17290	79	585
	RE48-3/4	RE48-3/4-3	3/4	370	17339	13700	7389	2244	70	650
	RE48-1	RE48-1-3	1	410	19188	16078	10903	4037	71	660
54"	RE48-1 1/2	RE48-1 1/2-3	1.5	465	21731	19010	14991	7081	72	665
	RE48-2	RE48-2-3	2	520	24274	21943	19080	10125	74	680
	-----	RE48-3-3	3	680	28150	25683	23615	16930	80	700
	-----	RE48-5-3	5	800	33160	30900	29290	25000	83	720
	RE54-1	RE54-1-3	1	410	23130	20588	17500	9600	73	910
60"	RE54-1 1/2	RE54-1 1/2-3	1.5	450	25400	22600	19300	10316	75	920
	RE54-2	RE54-2-3	2	480	27200	24312	20660	11010	76	930
	-----	RE54-3-3	3	550	31213	28722	25830	15420	77	940
	-----	RE54-5-3	5	660	37458	35238	32893	26538	80	960
60"	RE60-1	RE60-1-3	1	250	23090	19161	12850	-----	76	1150
	RE60-1 1/2	RE60-1 1/2-3	1.5	340	28068	23283	15624	8000	77	1150
	RE60-2	RE60-2-3	2	390	32200	26710	17924	9380	78	1200
	-----	RE60-3-3	3	450	37183	32356	25324	15013	84	1220
	-----	RE60-5-3	5	540	44600	41232	35819	23237	86	1240
-----	RE60-7 1/2-3	7.5	620	50184	47603	43981	32880	89	1285	

Note: Products listed in this section are custom built and subject to 100% cancellation/restocking charges

# Direct Drive Roof Ventilators



## Features

- Cast aluminum blades on most models
- Totally enclosed and explosion proof motors
- 1-Phase motors are field convertible 115V/230V
- 3-Phase motors are field convertible 230V/460V
- Motors are set to lower voltage at the factory unless a request is made at time of order to set them to the higher voltage
- Explosion proof motors are Class 1, Div 1, Group D and Class 2, Div 1, Groups F & G
- Wind band is 18 gauge galvanized steel
- Rubber shim under dampers for better seal
- Size of roof opening to be 6" larger than fan size
- Some models available with low R.P.M. motor for quieter operation
- 1 year limited warranty

**WARNING:** This product can expose you to chemicals including nickel which is known to the State of California to cause cancer, and chromium, which is known to the State of California to cause birth defects and/or reproductive harm. For more information go to [www.P65Warnings.ca.gov](http://www.P65Warnings.ca.gov).

## Options

- Protective coating
- Prefabricated curbs
- Disconnect switch

## Standard Models

BLADE SIZE	1-PHASE 115/230V	3-PHASE 208/230/460v	HP	RPM	C.F.M - STATIC PRESSURE				Db's @ 10'	WT. (LBS)
	MFG MODEL NUMBER				0"	1/8"	1/4"	1/2"		
18"	UED18-1/4	UED18-1/4-3	1/4	1140	2570	2263	1673	854	66	170
	UED18-1/3	UED18-1/3-3	1/3	1725	3375	3000	2600	1400	75	175
	UED18-1/2	UED18-1/2-3	1/2	1725	4133	3938	3724	3132	76	180
	UED18-1	UED18-1-3	1	1725	4600	4375	4080	3000	77	190
24"	UED24-1/4	UED24-1/4-3	1/4	1725	5200	4200	2820	----	75	240
	UED24-3/4	UED24-3/4-3	3/4	1140	6900	6450	6265	3300	76	260
	UED24-1	UED24-1-3	1	1725	7425	7000	6350	5000	83	280
	-----	UED24-3-3	3	1725	10500	9800	9500	8700	85	295
30"	UED30-3/4	UED30-3/4-3	3/4	1140	10440	9750	8750	6000	79	310
	-----	UED30-1-3	1	870	10800	10100	9100	6360	74	330
	UED30-1 1/2	UED30-1 1/2-3	1.5	1140	10410	9686	8834	6420	81	325
	UED30-2	UED30-2-3	2	1140	14000	13750	12900	10450	82	335
	-----	UED30-3-3	3	1725	16000	15350	14700	12900	89	335
36"	UED36-2	UED36-2-3	2	1140	17620	16500	15200	12300	84	430
	-----	UED36-3-3	3	1140	20500	19500	18500	15850	85	455
	-----	UED36-5-3	5	1140	22600	21700	20500	19000	87	465
42"	UED42-2	UED42-2-3	2	1140	17964	17277	15326	12351	88	500
	-----	UED42-5-3	5	1140	28970	27960	26840	24200	89	500
48"	-----	UED48-3-3	3	1140	28600	26500	24400	20000	92	550
	-----	UED48-5-3	5	870	33000	31500	29750	25300	86	665
	-----	UED48-7 1/2-3	7.5	1140	37000	35100	32800	28000	94	740
	-----	UED48-10-3	10	1140	41000	39200	38300	35400	95	875
60"	-----	UED60-5-3	5	870	45200	41500	37000	26000	90	940
	-----	UED60-7 1/2-3	7.5	870	47000	45500	43600	38700	92	950

**Note: Products listed in this section are custom built and subject to 100% cancellation/restocking charges**

\*Not all EXP motors are 208v capable

## Dimensions

SIZE	MINIMUM ROOF HOLE SIZE (SQUARE)	WIND BAND OUTER DIMENSION	ROOF CURB OUTER DIMENSION (SQUARE)	WIND BAND HEIGHT
18"	28"	24"	33"	16"
24"	34"	30"	39"	19"
30"	40"	36"	45"	22"
36"	46"	42"	51"	25"
42"	52"	48"	57"	27"
48"	58"	54"	63"	30"
60"	70"	66"	75"	42"

# Belt Drive Roof Ventilators

## Features

- Standard blades are heavy gauge steel
- Totally enclosed motors
- 1-Phase motors are field convertible 115V/230V
- 3-Phase motors are field convertible 230V/460V
- Motors are set to lower voltage at factory unless a request is made at time of order to set them to the higher voltage
- Wind band is 18 gauge galvanized steel
- Galvanized steel butterfly damper with rubber stops and seals
- Size of the roof opening to be 6" larger than fan size (Wind Band O.D.) dimension
- 1 year limited warranty



**WARNING:** This product can expose you to chemicals including nickel which is known to the State of California to cause cancer, and chromium, which is known to the State of California to cause birth defects and/or reproductive harm. For more information go to [www.P65Warnings.ca.gov](http://www.P65Warnings.ca.gov).

## Options

- Protective coating
- Prefabricated curbs
- Disconnect switch

## Standard Models

BLADE SIZE	1-PHASE 115/230V	3-PHASE 208/230/460v	HP	RPM	C.F.M - STATIC PRESSURE				Db's @ 10'	WT. (LBS)
	MFG MODEL NUMBER				0"	1/8"	1/4"	1/2"		
24"	UEB24-1/3	UEB24-1/3-3	1/3	780	4900	4222	2807	800	64	300
	UEB24-1/2	UEB24-1/2-3	1/2	980	6219	5716	5661	2600	66	305
	UEB24-3/4	UEB24-3/4-3	3/4	1140	7090	6648	6144	4413	71	310
30"	UEB30-1/2	UEB30-1/2-3	1/2	640	8507	7170	4486	1373	64	350
	UEB30-3/4	UEB30-3/4-3	3/4	770	10235	9192	7657	3833	66	360
	UEB30-1	UEB30-1-3	1	975	10668	9959	8626	5184	70	370
36"	UEB36-1/2	UEB36-1/2-3	1/2	530	10500	8821	5985	2084	66	360
	UEB36-3/4	UEB36-3/4-3	3/4	605	11985	10583	8563	4017	68	370
	UEB36-1	UEB36-1-3	1	665	13174	11932	10299	5729	70	390
	UEB36-1 1/2	UEB36-1 1/2-3	1.5	720	13660	12012	9579	5000	72	395
42"	UEB42-3/4	UEB42-3/4-3	3/4	435	14040	11530	7633	3311	67	455
	UEB42-1	UEB42-1-3	1	490	15429	13194	10438	4668	69	465
	UEB42-1 1/2	UEB42-1 1/2-3	1.5	550	17420	15421	13117	7289	71	470
	UEB42-2	UEB42-2-3	2	725	20653	19128	17503	11319	74	485
	-----	UEB42-3-3	3	830	23645	22296	20984	17290	79	495
48"	UEB48-3/4	UEB48-3/4-3	3/4	370	17339	13700	7389	2244	70	505
	UEB48-1	UEB48-1-3	1	410	19188	16078	10903	4037	71	520
	UEB48-1 1/2	UEB48-1 1/2-3	1.5	465	21731	19010	14991	7081	72	535
	UEB48-2	UEB48-2-3	2	520	24274	21943	19080	10125	74	545
	-----	UEB48-3-3	3	680	28150	25683	23615	16930	80	560
54"	UEB54-1	UEB54-1-3	1	410	23130	20588	17500	9600	73	870
	UEB54-1 1/2	UEB54-1 1/2-3	1.5	450	25400	22600	19300	10316	75	880
	UEB54-2	UEB54-2-3	2	480	27200	24312	20660	11010	76	890
	-----	UEB54-3-3	3	550	31213	28722	25830	15420	80	900
	-----	UEB54-5-3	5	660	37458	35238	32843	26538	82	920
60"	UEB60-1 1/2	UEB60-1 1/2-3	1.5	340	28068	23203	15624	8000	78	940
	UEB60-2	UEB60-2-3	2	390	32200	26710	17924	9380	80	960
	-----	UEB60-3-3	3	450	37183	32356	25324	15013	84	985
	-----	UEB60-5-3	5	540	44600	41232	35819	23237	86	1000

Note: Products listed in this section are custom built and subject to 100% cancellation/restocking charges

## Dimensions

SIZE	MINIMUM ROOF HOLE SIZE (SQUARE)	WIND BAND OUTER DIMENSION	ROOF CURB OUTER DIMENSION (SQUARE)	WIND BAND HEIGHT
24"	34"	30"	39"	19"
30"	40"	36"	45"	22"
36"	46"	42"	51"	25"
42"	52"	48"	57"	27"
48"	58"	54"	63"	30"
54"	64"	60"	69"	36"
60"	70"	66"	75"	42"

# Tubeaxial Direct Drive Duct Fans



## Features

- Totally enclosed and explosion proof motors
- 1-Phase motors are field convertible 115V/230V
- 3-Phase motors are field convertible 230V/460V
- Motors are set to lower voltage at the factory unless a request is made at time of order to set them to the higher voltage
- Explosion proof motors are Class 1, Div 1, Group D and Class 2, Div 1, Groups F & G
- 14 gauge steel drum including mounting flanges
- Fan can be mounted to operate in any position
- Rugged cast aluminum blade, non-sparking
- 1 year limited warranty

## Dimensions

SIZE	HOUSING I.NNER DIM.	HOUSING OUTER DIM.	BOLT HOLE CENTERS	HOUSING DEPTH
12"	12"	14"	13 1/8"	14"
18"	18"	20"	19 1/8"	14"
24"	24"	27"	25 3/4 "	18"
27"	27"	30"	28 3/4"	18"
30"	30"	33"	31 3/4"	18"
34"	34"	37"	35 3/4"	18"
42"	42"	45"	43 9/16"	18"
48"	48"	51"	49 5/8"	18"

**⚠ WARNING:** This product can expose you to chemicals including nickel which is known to the State of California to cause cancer, and chromium, which is known to the State of California to cause birth defects and/or reproductive harm. For more information go to [www.P65Warnings.ca.gov](http://www.P65Warnings.ca.gov).

## Options

- Companion flanges
- Fan guards
- Protective coating
- Access doors

## Standard Models

BLADE SIZE	1-PHASE 115/230V	3-PHASE 230/460v	HP	RPM	BLADES	C.F.M - STATIC PRESSURE				Db's @ 10'	WT. (LBS)
	MFG MODEL NUMBER					0"	1/4"	1/2"	3/4"		
12"	TXD12-1/4	TXD12-1/4-3	1/4	1725	4	1180	520	----	----	77	40
	TXD12-1/2	TXD12-1/2-3	1/2	3450	4	1875	1400	1250	1100	82	45
	TXD12-3/4	TXD12-3/4-3	3/4	3450	6	2044	1920	1650	1500	83	45
18"	TXD18-1/4	TXD18-1/4-3	1/4	1725	4	3450	2500	----	----	74	55
	TXD18-1/3	TXD18-1/3-3	1/3	1725	6	3375	2600	1400	----	75	65
	TXD18-1/2	TXD18-1/2-3	1/2	1725	6	4150	3150	1700	----	77	65
	TXD18-1	TXD18-1-3	1	1725	6	4600	4080	3000	2100	80	70
24"	TXD24-1/4	TXD24-1/4-3	1/4	1725	2	5200	2820	----	----	80	95
	TXD24-1/3	TXD24-1/3-3	1/3	1140	6	4975	4250	2850	----	74	110
	TXD24-1/2	TXD24-1/2-3	1/2	1725	4	6510	5200	3100	1800	80	115
	TXD24-3/4	TXD24-3/4-3	3/4	1140	6	6900	6265	3300	----	74	125
	TXD24-1	TXD24-1-3	1	1725	6	7425	6350	5000	3300	82	120
	TXD24-2	TXD24-2-3	2	1725	6	9525	8810	7980	6960	84	120
27"	-----	TXD24-3-3	3	1725	6	10500	9500	8700	7800	86	130
	TXD27-1/2	TXD27-1/2-3	1/2	1725	4	7550	6000	4000	2000	86	125
	TXD27-1	TXD27-1-3	1	1725	4	9600	8400	7050	4800	86	155
	TXD27-2	TXD27-2-3	2	1725	6	11500	10700	9300	8000	86	165
30"	TXD30-1/2	TXD30-1/2-3	1/2	1725	4	8980	6300	4350	2300	86	130
	TXD30-3/4	TXD30-3/4-3	3/4	1140	6	10440	8750	6000	----	80	150
	TXD30-2	TXD30-2-3	2	1725	6	12000	10450	8700	6000	89	155
	-----	TXD30-3-3	3	1725	6	16000	14700	12900	10200	89	175
34"	TXD34-1 1/2	TXD34-1 1/2-3	1.5	1725	4	13350	10000	7300	----	88	175
	TXD34-2	TXD34-2-3	2	1725	4	14850	12100	8800	4000	89	200
	-----	TXD34-3-3	3	1140	3	19300	17230	14800	11614	86	250
	-----	TXD34-5-3	5	1725	6	21000	18900	17500	14850	91	220
36"	TXD36-2	TXD36-2-3	2	1140	6	17620	15200	12300	8500	84	210
	-----	TXD36-3-3	3	1725	4	18500	15700	13900	11500	89	230
	-----	TXD42-1-3	1	870	4	15800	13480	5800	900	81	270
42"	TXD42-2	TXD42-2-3	2	1140	4	17964	15326	12351	7600	87	260
	-----	TXD42-3-3	3	1140	4	24500	23000	19650	14000	87	260
	-----	TXD42-5-3	5	1140	4	28970	26840	24200	19500	87	300
	-----	TXD48-3-3	3	1140	4	28600	24400	20000	15900	94	290
48"	-----	TXD48-5-3	5	870	4	33000	29750	25300	18000	86	500

## Duct Fan Guards

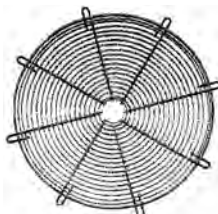

### Features

- Enamel finish
- Can be used as front or rear guards. (Rear guard for TXD models must be ordered with fan)

**⚠ WARNING:** This product can expose you to chemicals including nickel which is known to the State of California to cause cancer, and chromium, which is known to the State of California to cause birth defects and/or reproductive harm. For more information go to [www.P65Warnings.ca.gov](http://www.P65Warnings.ca.gov).

### Standard Models

FAN SIZE	MFG MODEL	FAN SIZE	MFG MODEL
12"	TXG-12	30"	TXG-30
15"	TXG-15	34"	TXG-34
18"	TXG-18	36"	TXG-36
24"	TXG-24	42"	TXG-42
27"	TXG-27	48"	TXG-48

**Note:** Products listed in this section are custom built and subject to 100% cancellation/restocking charges



# Tubeaxial Belt Drive Duct Fans

## Features

- Eliminates fumes and vapors from paint spray booths and other hazardous areas
- Totally enclosed and explosion proof motors
- 1-Phase motors are field convertible 115V/230V
- 3-Phase motors are field convertible 230V/460V
- Motors are set to lower voltage at the factory unless a request is made at time of order to set them to the higher voltage
- Explosion proof motors are Class 1, Div 1, Group D and Class 2, Div 1, Groups F & G
- Recommended for most paint spray applications because motor is out of air
- 14 gauge steel drum including mounting flanges at each end
- Completely enclosed belt and ball bearing housing
- Adjustable motor base for proper belt tension
- Rugged cast aluminum blade, non-sparking
- Fan can be mounted to operate in any position
- 1 year limited warranty

**WARNING:** This product can expose you to chemicals including nickel which is known to the State of California to cause cancer, and chromium, which is known to the State of California to cause birth defects and/or reproductive harm. For more information go to [www.P65Warnings.ca.gov](http://www.P65Warnings.ca.gov).



## Options

- Companion flanges
- Protective coating
- Access doors
- Belt guards
- Motor covers
- Fan guards

## Standard Models

BLADE SIZE	1-PHASE 115/230V-60Hz	3-PHASE 230/460v-60Hz	HP	RPM	BLADES	C.F.M - STATIC PRESSURE				Db's @10'	WT (LBS)
	MFG MODEL NUMBER					0"	1/4"	1/2"	3/4"		
12"	TXB12-1/4	TXB12-1/4-3	1/4	2625	4	1444	1033	380	----	77	62
	TXB12-1/3	TXB12-1/3-3	1/3	2875	4	1586	1135	415	----	78	65
	TXB12-1/2	TXB12-1/2-3	1/2	3450	4	1875	1400	1250	1100	83	65
	TXB12-3/4	TXB12-3/4-3	3/4	3450	6	2044	1920	1650	1500	83	67
15"	TXB15-1/4	TXB15-1/4-3	1/4	2000	6	2600	1700		----	77	67
	TXB15-1/3	TXB15-1/3-3	1/3	2200	6	2950	2100	1000	----	78	69
	TXB15-1/2	TXB15-1/2-3	1/2	1890	6	3350	2650	1500	----	76	75
	TXB15-3/4	TXB15-3/4-3	3/4	2200	6	3900	3400	2700	1150	78	85
18"	TXB18-1/4	TXB18-1/4-3	1/4	1600	6	3050	2000		----	76	80
	TXB18-1/3	TXB18-1/3-3	1/3	1725	6	3375	2600	1400	----	77	85
	TXB18-1/2	TXB18-1/2-3	1/2	1890	6	3850	3100	2000	----	78	95
	TXB18-1	TXB18-1-3	1	1725	6	4600	4080	3000	2100	77	105
24"	TXB18-1 1/2	TXB18-1 1/2-3	1.5	1990	6	5350	4830	3950	3000	80	105
	TXB24-1/2	TXB24-1/2-3	1/2	1298	6	5643	4826	3500	----	78	120
	TXB24-3/4	TXB24-3/4-3	3/4	1600	6	6906	5900	4650	2750	80	130
	TXB24-1	TXB24-1-3	1	1725	6	7425	6350	5000	3300	84	140
	TXB24-1 1/2	TXB24-1 1/2-3	1.5	1540	6	8200	7650	6850	5500	81	145
	TXB24-2	TXB24-2-3	2	1600	6	9760	8830	8090	7000	82	170
27"	-----	TXB24-3-3	3	1725	6	10500	9500	8700	7800	86	190
	TXB27-3/4	TXB27-3/4-3	3/4	1250	6	8330	7550	6500	4650	78	150
	TXB27-1	TXB27-1-3	1	1400	6	9400	8480	7300	5200	82	155
	TXB27-1 1/2	TXB27-1 1/2-3	1.5	1600	6	10700	9700	8375	6000	84	170
	TXB27-2	TXB27-2-3	2	1350	6	11500	10700	9300	8000	81	210
	TXB30-1/2	TXB30-1/2-3	1/2	1140	4	8900	6660	2300	----	79	140
30"	TXB30-1	TXB30-1-3	1	1298	6	9867	7980	4120	----	82	150
	TXB30-1 1/2	TXB30-1 1/2-3	1.5	1035	6	11100	9700	7500	3500	78	165
	TXB30-2	TXB30-2-3	2	1176	6	12100	11000	9322	6700	81	215
	-----	TXB30-3-3	3	1350	6	13480	12498	11465	10380	84	215
	-----	TXB30-5-3	5	1650	6	16440	15242	13982	12659	88	230
34"	TXB34-1 1/2	TXB34-1 1/2-3	1.5	1170	6	13695	11100	6000	1015	82	190
	TXB34-2	TXB34-2-3	2	1027	6	14657	12590	10000	8000	81	240
	-----	TXB34-3-3	3	1175	6	17580	15896	14095	12000	85	260
	-----	TXB34-5-3	5	1416	6	20500	19000	17500	16000	88	305
42"	TXB42-1 1/2	TXB42-1 1/2-3	1.5	750	4	18960	14662	7200	----	78	250
	TXB42-2	TXB42-2-3	2	820	4	20700	17002	11400	4000	80	260
	-----	TXB42-3-3	3	890	4	23700	20200	16970	9950	82	260
	-----	TXB42-5-3	5	850	6	26900	24403	22250	18400	82	270
48"	-----	TXB48-5-3	5	800	6	33000	29000	25600	20000	85	375
	-----	TXB48-7 1/2-3	7.5	900	6	37000	34500	31000	27000	87	520

SIZE	HOUSING INNER DIMENSION	HOUSING OUTER DIMENSION	BOLT HOLE CENTERS	HOUSING DEPTH
12"	12"	14"	13 1/8"	12"
15"	15"	17"	16 1/8"	12"
18"	18"	20"	19 1/8"	12"
24"	24"	27"	25 3/4"	12" & 16"
27"	27"	30"	28 3/4"	16"
30"	30"	33"	31 3/4"	16"
34"	34"	37"	35 3/4"	16"
42"	42"	45"	43 1/16"	18"
48"	48"	51"	49 1/8"	24"

Note: Products listed in this section are custom built and subject to 100% cancellation/restocking charges

# Attic Fans

## Power Attic Mount Dome Ventilator



**WARNING:** This product can expose you to chemicals including nickel which is known to the State of California to cause cancer, and chromium, which is known to the State of California to cause birth defects and/or reproductive harm. For more information go to [www.P65Warnings.ca.gov](http://www.P65Warnings.ca.gov).

### Features

- 120V Motor / 1-Phase
- Automatic thermostat (60°-120°F)
- Insect and bird screen installed
- Black or brown painted finish or mill finish
- Made in U.S.A.

Note: Photograph is a representation of stocked models. Actual model may vary in appearance.

### Standard Models

MFG CATALOG NUMBER	MFG MODEL NUMBER	DOMES COLOR	SPEED	CFM .03 SP	VOLTS	HP	RPM	ATTIC SIZE / SQ. FT.*	WT. (LBS)
08664202	PDV-305-1MB-GY-G	Mill	1	1000	120	1/12	1050	Average/1600	19
08664302	PDV-305-1MB-BR-G	Brown	1	1000	120	1/12	1050	Average/1600	19
08664402	PDV-305-1MB-BLK-G	Black	1	1000	120	1/12	1050	Average/1600	19

\*@ 4:12 Pitch Roof

## Gable Exhaust Fan



Damper requires 16 1/2" x 16 1/2" opening

**WARNING:** This product can expose you to chemicals including nickel which is known to the State of California to cause cancer, and chromium, which is known to the State of California to cause birth defects and/or reproductive harm. For more information go to [www.P65Warnings.ca.gov](http://www.P65Warnings.ca.gov).



### Features

- 120V motor / 1-Phase
- Automatic adjustable thermostat (60°-120°F)
- Partially assembled (mounting tabs must be assembled)
- 14" blade diameter
- 4 mounting tabs on 16" centers
- Made in U.S.A.

### Standard Models

MFG CATALOG NUMBER	MFG MODEL NUMBER	DESCRIPTION	CFM .03 SP	ATTIC SIZE/ SQ. FT.*	WT. (LBS)
08663702	GV-405-2B-G	Gable Mount Ventilator	1540	Average/2400	13
08665202	AGD-1416B-G	White Aluminum Damper for GV-405-2B-G	----	----	3

\*@ 4:12 Pitch Roof

## Belt Drive Wholehouse Fans



**WARNING:** This product can expose you to chemicals including nickel which is known to the State of California to cause cancer, and chromium, which is known to the State of California to cause birth defects and/or reproductive harm. For more information go to [www.P65Warnings.ca.gov](http://www.P65Warnings.ca.gov).

### Features

- 120V, 1-Phase, 2-Speed motors
- Shutters automatically open when fan is turned on and close tightly when fan is turned off
- Made in U.S.A.

NOTE: Belt Drive Fan with "No Joist Cut" Shutter

### Standard Models

MFG CATALOG NUMBER	MFG MODEL NUMBER	SIZE	SPEED	MOTOR HP	CFM @ .1 IN. H2O PRESSURE DROP w/ SHUTTER	FAN SPEED RPM	FAN MOUNTING DIMENSIONS (IN)			EXHAUST SQ. FT. REQ'D	AMPS	WT. (LBS)
							A	B	C			
07936202	BD24-2-WHS	24"	2	1/3	4500/2700	612/410	28	29.5	14.5	7	5.7/4.8	40
07936302	BD30-2-WHS	30"	2	1/3	7600/5800	520/350	34	35.5	14.5	9	6.9/5.5	50
07936402	BD36-2-WHS	36"	2	1/3	9675/6400	395/265	40	41.5	14.5	12	6.3/3.1	64

### Fan Dimensions

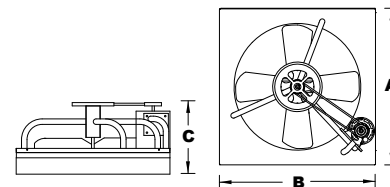

### Ceiling Shutters

MFG CATALOG NUMBER	MFG MODEL NUMBER	FIT HOLE SIZE (I.D.)	OUTSIDE SIZE (O.D.)	FAN SIZE	WT. (LBS)
07944802	CS-10-W	26X26	28X28	24"	8
07944602	CS-13-W	32X34	34X36	30"	10
07945302	CS-14-W	34X34	36X36	30"	10
07944702	CS-18-W	32X43	34X45	36"	11
07945202	CS-19-W	34X43	36X45	36"	11

"Joist out style" (for replacement only)

### Control Options

MFG CATALOG NUMBER	MFG MODEL NUMBER	DESCRIPTION	WT. (LBS)
07927002	2-SW	2 Speed wall switch & plate	1
05000802	1A22-7	SP Close on rise (Attic Thermostat) (80°-130°F)	1

**WARNING:** This product can expose you to chemicals including nickel which is known to the State of California to cause cancer, and chromium, which is known to the State of California to cause birth defects and/or reproductive harm. For more information go to [www.P65Warnings.ca.gov](http://www.P65Warnings.ca.gov).

# Loading Dock Lights - Shipped in 1-Carton

## Light Head Features

- Chip resistant safety yellow & black powder coating finish for high visibility and durability
- 5' long 18/3 SJT, 120V cordset with NEMA 15-5 grounded plug
- On/Off switch & wire guard included on each light head
- 1-1/2" square, 11-gauge, steel tubing
- 3" x 5" x 3/16" mounting plate attached with (4) 3/8" bolts (not supplied)
- VA & DKLED models have vertical adjustment bracket allowing outer arm to adjust from 300° horizontally and 210° vertically
- All light heads will swivel 300°
- VA Models include an embedded electrical outlet for direct plug connection from the light head fixture and shipped fully-assembled
- DKLED units contain a die-cast aluminum light head with adjustable knobs, built-in on/off switch, and maintains an IP65 rating suitable for wet locations
- DKLED units use a 20° custom beam angle and 12 individual high-intensity LED emitters generating a neutral white color; with a CCT measuring 4,000K DKLED units provide a minimum life of 50,000 hours and offers a 5-year warranty, including CE & RoHS Certificates
- Designed for loading dock and work station environments
- ETL C/US Listed for indoor applications only, except QH models are semi-protected outdoor and DKLED models have IP65 rating suitable for wet location areas



DKL-40VA-A

Flexible elastomer arm moves when hit and then returns light to original position



DKL-25-FLX

LED 30-Watt



DKLED-40-30W



**WARNING:** This product can expose you to chemicals including nickel which is known to the State of California to cause cancer, and chromium, which is known to the State of California to cause birth defects and/or reproductive harm. For more information go to [www.P65Warnings.ca.gov](http://www.P65Warnings.ca.gov).

## Standard Models (120V)

MFG CATALOG NUMBER	MFG MODEL NUMBER	ARM LENGTH	# OF ARMS	MAX WATTS	WT. (LBS)
<b>NO BULB</b>					
04466502	DKL-40VA-A	40"	2	Maximum 300	14
04466602	DKL-60VA-A	60"	2		17
03854001	DKL-25-FLX	25"	1		17
<b>LED - 3,300 Lumens, 4,000K CCT, 50,000-hour Avg. Bulb Life</b>					
04922802	DKLED-40-30W	40"	2	30	13
04922902	DKLED-42-30W	42"	3		14

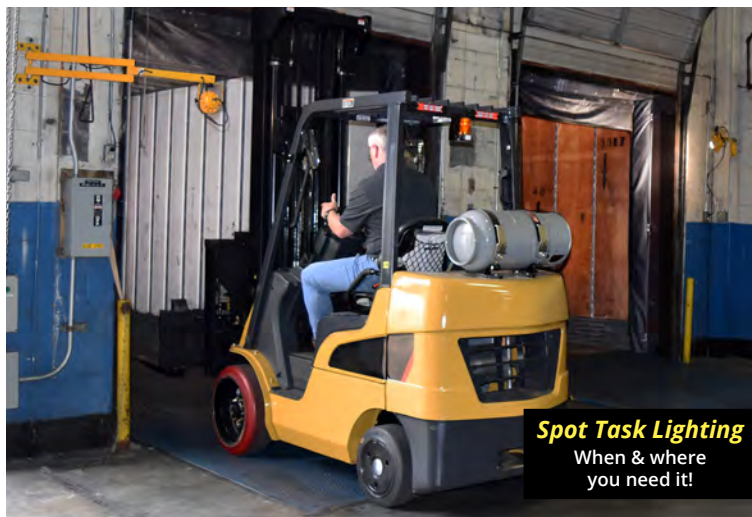

**Spot Task Lighting**  
When & where you need it!



DKLED-42-30W



# Loading Dock Lights - Modular (shipped in multiple cartons)

## Modular Lights



DKLED-30W-WP



DKL-INC



DKL-LED-30W-SP



DKL-LED37

### Features

- 14" long, 18/3 conductor cord plugs into electrical junction box on arm
- On/Off switch & wire guard included with each light head
- Bulb included with all light heads except DKL-INC
- Imported to TPI specifications.
- DKL-LED-37 is compliant with ROHS 2 Directive (2011/65/EU), that of which includes the application exemptions outlined in Annex III of the directive.



**WARNING:** This product can expose you to chemicals including nickel which is known to the State of California to cause cancer, and chromium, which is known to the State of California to cause birth defects and/or reproductive harm. For more information go to [www.P65Warnings.ca.gov](http://www.P65Warnings.ca.gov).

## Standard Models

MFG CATALOG NUMBER	MFG MODEL NUMBER	LIGHT HEAD TYPE	MAX WATTS	MAX LUMENS	AVE. BULB LIFE (HRS)	WT. (LBS)
04465602	DKL-INC	No Bulb Included	300	3,700	2,000	5
04881302	DKL-LED-37	LED	37	2,373	> 30,000	5
04923002	DKLED-30W-WP	LED w/ Pin Connector Plug	30	3,300	50,000	7
04923102	DKLED-30W-SP	LED w/ Grounded Plug	30	3,300	50,000	7

## Mounting Arms



DKL-40VA-ARM



60-LDA



24-LDA



The outer arm on 40VA & 60VA arms will swing 300° in horizontal plane & 210° in vertical plane

**WARNING:** This product can expose you to chemicals including nickel which is known to the State of California to cause cancer, and chromium, which is known to the State of California to cause birth defects and/or reproductive harm. For more information go to [www.P65Warnings.ca.gov](http://www.P65Warnings.ca.gov).

### Features

- 1-1/2" square, 11 gauge, steel tubing
- 3" x 5" x 1/2" mounting plate attaches with (4) 1/2" bolts
- 5' long, 18/3 SJTW conductor cord and NEMA 5-15 grounded plug
- Made in U.S.A.

## Standard Models

MFG CATALOG NUMBER	MFG MODEL NUMBER	ARM LENGTH	TOTAL # OF ARMS	WT. (LBS)
04465302	24-LDA	24"	1	11
04466102	40-LDA**	40"	3	18
04466202	60-LDA**	60"	3	24

\*\*Indicates heavy duty dock arms (Horizontal swing only, no vertical movement)

## Loading Dock Arm Fan



**WARNING:** This product can expose you to chemicals including nickel which is known to the State of California to cause cancer, and chromium, which is known to the State of California to cause birth defects and/or reproductive harm. For more information go to [www.P65Warnings.ca.gov](http://www.P65Warnings.ca.gov).

### Features

- 18" high velocity circulator, with 3 speed, 1/8 HP, 115V, 1 phase permanently lubricated, totally enclosed, PSC motor
- Modular fan plugs into electrical outlet on arm
- Coated steel guards and aluminum blades
- Imported to TPI specifications

## Standard Models

MFG CATALOG NUMBER	MFG MODEL NUMBER	CFM			VELOCITY PROFILE MAX. CFM	AMPS HIGH	WT. (LBS)
		HIGH	MED	LOW			
07971802	LDF-18-TE	1800	1500	1300	2900	2.2	20

Note: Must be used with LDA (Heavy Duty) mounting arms

# Machine Tool Lights

## Water Resistant Fluorescent or LED Tube Lights



23-TLP-24VDC

**WARNING:** This product can expose you to chemicals including nickel which is known to the State of California to cause cancer, and chromium, which is known to the State of California to cause birth defects and/or reproductive harm. For more information go to [www.P65Warnings.ca.gov](http://www.P65Warnings.ca.gov).



29-LED



21-LED

### Features

- All tube lights come standard with a durable, lightweight, economical, shatter-resistant polycarbonate tube housing
- Stainless steel mounting brackets (2), fasteners and threaded conduit fitting included with all models
- LEDTLP Models are ETL C/US Listed for NEMA Type 13 applications - oil / water / coolant spray areas (not submersible) and dusty atmospheres
- LED Models operate at 120V and include an 8' long, 18/3 SJTOW cord with NEMA 5-15 grounded plug
- LED Models comply with part-15 of the FCC rule
- Model 21-LEDTLP-120-16 includes an aluminum enclosure with on/off power switch
- Model 21-LED generates 100-watts of an incandescent light output equivalent, but only consumes 16-watts of power; Model 29-LED generates 150-watts, using only 26-watts of power.
- 23-TLP-24VDC uses a fluorescent bulb and operates at low voltage of 24V DC, includes on board ballast and 2' long lead wires for direct connection; unit is NOT ETL Listed
- All units are made in the U.S.A.

### Standard Models

MFG CATALOG NUMBER	MFG MODEL NUMBER	DESCRIPTION	WATTS	VOLTS	LUMENS	OVERALL LENGTH	TUBE MATERIAL	BALLAST INCLUDED	WT. (LBS)
04829302	23-TLP-24VDC	Fluorescent w/wire leads	18	24VDC	1250	23"	Polycarbonate	Yes	6
04891802	21-LEDTLP-120-16	LED, on/off switch enclosure & cordset	16	120V	1200	21"	Polycarbonate	No	4
04891902	29-LEDTLP-120-26	LED, with cordset	26	120V	2800	29"	Polycarbonate	No	3

### Accessories - Replacement Lamps

MFG CATALOG NUMBER	MFG MODEL NUMBER	DESCRIPTION	USED WITH	WT. (LBS)
3103300	TL-RB-18	Fluorescent Replacement Bulb, 18W, PL-L	23-TLP-24VDC	1

## Commercial Duty Portable Utility Lights

### CL 300 (Clamp on Model)

### Features



**WARNING:** This product can expose you to chemicals including nickel which is known to the State of California to cause cancer, and chromium, which is known to the State of California to cause birth defects and/or reproductive harm. For more information go to [www.P65Warnings.ca.gov](http://www.P65Warnings.ca.gov).

- Ceramic socket will accept incandescent bulbs A-19, R-40 or PAR bulbs up to 300 Watt. Fixture will also accept infrared heat lamps up to 250 Watts
- 11-watt LED bulb included
- 8' long - 18/3 SPT cordset with NEMA 5-15 plug
- Imported to TPI specifications.

MFG CATALOG NUMBER	MFG MODEL NUMBER	BASE TYPE	DESCRIPTION	MAX. WATTS	VOLTS	MAX LUMENS	AVE. BULB LIFE HOURS	WT. (LBS)
02804900	CL-300	CLIP-ON	11-Watt, LED	300	120	800	25,000	3

CL-300 is shipped in ONE carton. LED bulb included.

# Product Index Listing

MODEL	PAGE	MODEL	PAGE	MODEL	PAGE	MODEL	PAGE
1A22-7	41	CACU 24-PO	8	CE 24-DV	25	CESM-30	32
2-SW	41	CACU 24-W	8	CE 30-D	24	CESM-36	32
21-LEDTLP-120-16	44	CACU 24-WO	8	CE 30-DS	23	CESM-42	32
29-LEDTLP-120-26	44	CACU 30-P	8	CE 30-DV	25	CESM-48	32
23-TLP-24VDC	44	CACU 30-P-HD	8	CE-24B	26	CESM-60	32
24-LDA	43	CACU 30-PO	8	CE-24B-3	26	CF-12	20
24-LDF-TE	21	CACU 30-PO-HD	8	CE-30B	26	CF-18	20
40-LDA	43	CACU 30-W	8	CE-30B-3	26	CF-20	20
40-LDF-TE	21	CACU 30-WO	8	CE-36B	26	CL-300	44
60-LDA	43	CAS - 18	16	CE-36B-3	26	CPB 30-D	9
60-LDF-TE	21	CAS - 48	16	CE-42B	26	CPB 36-B	9
ACH 20	3	CBT-24B	30	CE-42-B-3	26	CPB 36-D	9
ACH 20-O	3	CBT-24B-3	31	CE-48B	26	CPB 42-B	9
ACH 24	3	CBT-30B	31	CE-48-B-3	26	CPB 48-B	9
ACH 24-EX1	5	CBT-30B-3	31	CEFP-12	34	CPBS 24-DHV	9
ACH 24-EX3	5	CBT-36B	31	CEFP-16	34	CPBS 30-D	9
ACH 24-O	3	CBT-36B-3	31	CEFP-18	34	CS-10-W	41
ACH 24-TE3	5	CBT-42B	31	CEFP-20	34	CS-13-W	41
ACH 30-TE3	5	CBT-42B-3	31	CEFP-24	34	CS-14-W	41
ACH 30	3	CBT-48B	31	CEFP-30	34	CS-18-W	41
ACH 30-EX1	5	CBT-48B-3	31	CEFP-36	34	CS-19-W	41
ACH 30-EX3	5	CD-18	35	CEFP-42	34	DKL-25-FLX	42
ACH 30-O	3	CD-24	35	CEFP-48	34	DKL-40VA-A	42
ACM-C	6	CD-30	35	CEFP-60	34	DKL-40VA-ARM	43
ACM-I	6	CD-36	35	CES 12-HD	32	DKL-60VA-A	42
ACM-P	6	CD-42	35	CES 16-HD	32	DKL-60VA-ARM	43
ACM-PM	6	CD-48	35	CES 18-HD	32	DKL-INC	21, 43
ACM-S	6	CD-54	35	CES 20-HD	32	DKLED-30W-WP	43
ACM-W	6	CD-60	35	CES 24-HD	32	DKLED-30W-SP	43
ACM-WK	6	CE 10-D	24	CES 30-HD	32	DKLED-40-30W	42
ACU 20-P	4	CE 10-DS	23	CES 36-HD	32	DKLED-42-30W	42
ACU 20-PO	4	CE 10-DV	25	CES 42-HD	32	DKL-LED-37	43
ACU 20-W	4	CE 12-D	24	CES 48-HD	32	DKL-QH	21, 43
ACU 20-WO	4	CE 12-DS	23	CES 54-HD	32	DMKP1	34
ACU 24-P	4	CE 12-DV	25	CES 60-HD	33	DMKP2	35
ACU 24-PO	4	CE 14-D	25	CES-10G	24, 25	DR36	24
ACU 24-W	4	CE 14-DS	23	CES-12G	24, 25	E-56CF	22
ACU 24-WO	4	CE 14-DV	25	CES-14G	24, 25	E-60CF	22
ACU 30-P	4	CE 16-D	24	CES-16G	24, 25	E-60CFC	22
ACU 30-PO	4	CE 16-DS	23	CES-18G	24, 25	EHB24-1	30
ACU 30-W	4	CE 16-DV	25	CES-20G	24, 25	EHB24-1-3	30
ACU 30-WO	4	CE 18-D	24	CES-24	26	EHB24-1/2	30
AGD-1416B-G	41	CE 18-DS	23	CES-24G	24, 25	EHB24-1/2-3	30
BD24-2-WHS	41	CE 18-DV	25	CES-30	26	EHB24-1/4	30
BD30-2-WHS	41	CE 20-D	24	CES-30G	24, 25	EHB24-1/4-3	30
BD36-2-WHS	41	CE 20-DS	23	CES-36	26	EHB24-3/4	30
CACU 20-P	8	CE 20-DV	25	CES-42	26	EHB24-3/4-3	30
CACU 20-W	8	CE 24-D	24	CES-48	26	EHB30-1	30
CACU 24-P	8	CE 24-DS	23	CESM-24	32	EHB30-1 1/2	30

MODEL	PAGE	MODEL	PAGE	MODEL	PAGE	MODEL	PAGE
EHB30-1 1/2-3	30	EHB60-1 1/2-3	30	EHD36-5-3	29	HV-1	15
EHB30-1-3	30	EHB60-1-3	30	EHD42-1-3	29	HV-2	15
EHB30-1/2	30	EHB60-2	30	EHD42-2	29	HV-3	15
EHB30-1/2-3	30	EHB60-2-3	30	EHD42-2-3	29	HV-4-18	15
EHB30-1/3	30	EHB60-3-3	30	EHD42-3-3	29	HV-4-24	15
EHB30-1/3-3	30	EHB60-5-3	30	EHD42-5-3	29	HV-4-30	15
EHB30-1/4	30	EHD12-1/4	29	EHD48-3-3	29	HV-5-18	15
EHB30-1/4-3	30	EHD12-1/4-3	29	EHD48-5-3	29	HV-5-24	15
EHB30-3/4	30	EHD16-1/4	29	EHD60-10-3	29	HV-5-30	15
EHB30-3/4-3	30	EHD16-1/4-3	29	EHD60-3-3	29	HV-6-18	15
EHB36-1	30	EHD18-1/2	29	EHD60-5-5	29	HV-6-24	15
EHB36-1 1/2	30	EHD18-1/2-3	29	EHD60-7 1/2-3	29	HV-6-30	15
EHB36-1 1/2-3	30	EHD18-1/3	29	EMF-12	33	HV-7-DC-1	15
EHB36-1-3	30	EHD18-1/3-3	29	EMF-16	33	HV-7-DC-3	15
EHB36-1/2	30	EHD20-1	29	EMF-20	33	HV-8	15
EHB36-1/2-3	30	EHD20-1-3	29	EMF-24	33	HV18-120V	15
EHB36-1/3	30	EHD20-1/2	29	EMF-30	33	HV18-208/240V	15
EHB36-1/3-3	30	EHD20-1/2-3	29	EMF-36	33	HV18-277V	15
EHB36-2	30	EHD20-1/4	29	EMF-42	33	HV18-480V	15
EHB36-2-3	30	EHD20-1/4-3	29	EMF-48	33	HV24-120V	15
EHB36-3/4	30	EHD24-1	29	EMF-60	3	HV24-208/240V	15
EHB36-3/4-3	30	EHD24-1-3	29	F-12-TE	18	HV24-277V	15
EHB42-1	30	EHD24-1/2	29	F-18-TE	18	HV24-480V	15
EHB42-1 1/2	30	EHD24-1/2-3	29	F-18H-TE	18	HV30-120V	15
EHB42-1 1/2-3	30	EHD24-1/3	29	F-24-TE	18	HV30-208/240V	15
EHB42-1-3	30	EHD24-1/3-3	29	F-24-TE-HV	18	HV30-277V	15
EHB42-1/2	30	EHD24-1/4	29	F-24H-TE	18	HV30-480V	15
EHB42-1/2-3	30	EHD24-1/4-3	29	FLS-18	34	HV18-480V-3	15
EHB42-1/3	30	EHD24-2	29	FLS-24	35	HV24-480V-3	15
EHB42-1/3-3	30	EHD24-2-3	29	FLS-30	35	HV30-480V-3	15
EHB42-2	30	EHD24-3-3	29	FLS-36	35	IBG-12	33
EHB42-2-3	30	EHD24-3/4	29	FLS-42	35	IBG-16	33
EHB42-3-3	30	EHD24-3/4-3	29	FLS-48	35	IBG-18	33
EHB42-3/4	30	EHD30-1 1/2	29	FLS-54	35	IBG-20	33
EHB42-3/4-3	30	EHD30-1 1/2-3	29	FLS-60	35	IBG-24	33
EHB48-1	30	EHD30-1-3	29	GV-405-2B-G	41	IBG-30	33
EHB48-1 1/2	30	EHD30-1/2	29	HDH 24	2	IBG-36	33
EHB48-1 1/2-3	30	EHD30-1/2-3	29	HDH 24-G	3	IBG-42	33
EHB48-1-3	30	EHD30-1/3	29	HDH 24-GJR	3	IBG-48	33
EHB48-1/2	30	EHD30-1/3-3	29	HDH 24-JR	2	IBG-60	33
EHB48-1/2-3	30	EHD30-2	29	HDH 30	2	IE24-1	28
EHB48-2	30	EHD30-2-3	29	HDH 30-G	3	IE24-1-3	28
EHB48-2-3	30	EHD30-3-3	29	HDH 30-GJR	3	IE24-1/2	28
EHB48-3-3	30	EHD30-3/4	29	HDH 30-JR	2	IE24-1/2-3	28
EHB48-3/4	30	EHD30-3/4-3	29	HDH 36	3	IE24-1/3	28
EHB48-3/4-3	30	EHD36-1	29	HDM-C	6	IE24-1/3-3	28
EHB48-5-3	30	EHD36-1-3	29	HDM-I	6	IE24-3/4	28
EHB60-1	30	EHD36-2-3	29	HDM-P	6	IE24-3/4-3	28
EHB60-1 1/2	30	EHD36-3-3	29	HDM-W	6	IE30-1	28

# Product Index Listing

MODEL	PAGE	MODEL	PAGE	MODEL	PAGE	MODEL	PAGE
IE30-1-3	28	IED20-3/4-3	27	MCD48-5	16	PM-2.5	19
IE30-1/2	28	IED24-1	27	MCD48-7 1/2	16	PM-3	19
IE30-1/2-3	28	IED24-1-3	27	MCD60-10	16	QH-2	43
IE30-1/3	28	IED30-1	27	MCD60-15	16	RDS-18	35
IE30-1/3-3	28	IED30-1-3	27	MCD60-3	16	RDS-24	35
IE30-3/4	28	IED36-1 1/2	27	MCD60-5	16	RDS-30	35
IE30-3/4-3	28	IED36-1 1/2-3	27	MCD60-7 1/2	16	RDS-36	35
IE36-1	28	IED42-2-3	27	MK-1	32	RDS-42	35
IE36-1 1/2	28	IED48-3-3	27	MK-2	32	RDS-48	35
IE36-1 1/2-3	28	IHP 20-H-WD	5	MK-3	32	RDS-54	35
IE36-1-3	28	IHP 24-H	3	N-12	21	RDS-60	35
IE36-1/2	28	IHP 24-H-277	5	ODF-12	20	RE24-1	36
IE36-1/2-3	28	IHP 24-H-WD	5	ODF-16	20	RE24-1-3	36
IE36-1/3	28	IHP 30-H	3	OSF-16	20	RE24-1/2	36
IE36-1/3-3	28	IHP 30-H-277	5	PBX 30-D	10	RE24-1/2-3	36
IE36-2	28	IHP 30-H-WD	5	PBX 36-B	11	RE24-1/4	36
IE36-2-3	28	KBWC-110K	22	PB 36-B-3	11	RE24-1/4-3	36
IE36-3/4	28	KBWC-15SK	22	PB 36-B-HL	11	RE24-3/4	36
IE36-3/4-3	28	LDF-18-TE	21, 43	PBX 36-D	10	RE24-3/4-3	36
IE42-1	28	MB 24-DF	13	PBX 42-B	11	RE30-1	36
IE42-1 1/2	28	MB 24-DY	13	PB 42-B-3	11	RE30-1 1/2	36
IE42-1 1/2-3	28	MB 30-DF	13	PB 42-B-HL	11	RE30-1 1/2-3	36
IE42-1-3	28	MB 30-DY	13	PBX 42-D	10	RE30-1-3	36
IE42-2	28	MBM-W	13	PBX 48-B	11	RE30-1/2	36
IE42-2-3	28	MCD18-1	16, 17	PB 48-B-3	11	RE30-1/2-3	36
IE42-3-3	28	MCD18-1/3	16, 17	PB 48-B-HL	11	RE30-1/3	36
IE42-3/4	28	MCD18-1/4	16, 17	PB 48-D-OP	10	RE30-1/3-3	36
IE42-3/4-3	28	MCD24-1	16, 17	PBSX 30-D	10	RE30-3/4	36
IE48-1	28	MCD24-1 1/2	16, 17	PBSX 36-B	11	RE30-3/4-3	36
IE48-1 1/2	28	MCD24-1/2	16, 17	PBS 36-B-3	11	RE36-1	36
IE48-1 1/2-3	28	MCD24-1/3	16, 17	PBS 36-B-HL	11	RE36-1 1/2	36
IE48-1-3	28	MCD24-1/4	16, 17	PBSX 36-D	10	RE36-1 1/2-3	36
IE48-2	28	MCD24-3	16, 17	PBSX 42-B	11	RE36-1-3	36
IE48-2-3	28	MCD24-3/4	16, 17	PBS 42-B-3	11	RE36-1/2	36
IE48-3-3	28	MCD30-1	16, 17	PBS 42-B-HL	11	RE36-1/2-3	36
IE48-3/4	28	MCD30-1 1/2	16, 17	PBSX 42-D	10	RE36-1/3	36
IE48-3/4-3	28	MCD30-1/2	16, 17	PBSX 48-B	11	RE36-1/3-3	36
IE48-5-3	28	MCD30-1/3	16, 17	PBS 48-B-3	11	RE36-2	36
IE60-2	28	MCD30-2	16, 17	PBS 48-B-HL	11	RE36-2-3	36
IE60-2-3	28	MCD30-3	16, 17	PBS 48-D-OP	10	RE36-3/4	36
IE60-3-3	28	MCD30-3/4	16, 17	PCBT 36-B	13	RE36-3/4-3	36
IE60-5-3	28	MCD36-1	16, 17	PCBT 42-B	13	RE42-1	36
IED12-1/4	27	MCD36-1 1/2	16, 17	PCBT 48-B	13	RE42-1 1/2	36
IED12-1/4-3	27	MCD36-2	16, 17	PDV-305-1MB-BLK-G	41	RE42-1 1/2-3	36
IED16-1/3	27	MCD36-3	16, 17	PDV-305-1MB-BR-G	41	RE42-1-3	36
IED16-1/3-3	27	MCD36-5	16, 17	PDV-305-1MB-GY-G	41	RE42-1/2	36
IED18-1/2	27	MCD42-2	16	PM-1	19	RE42-1/2-3	36
IED18-1/2-3	27	MCD42-5	16	PM-1.5	19	RE42-2	36
IED20-3/4	27	MCD48-10	16	PM-2	19	RE42-2-3	36



MODEL	PAGE	MODEL	PAGE	MODEL	PAGE	MODEL	PAGE
RE42-3-3	36	SLS-30	35	TXB18-1/4-3	40	TXD12-3/4-3	38
RE42-3/4	36	SLS-36	35	TXB24-1	40	TXD18-1	38
RE42-3/4-3	36	SLS-42	35	TXB24-1 1/2	40	TXD18-1-3	38
RE48-1	36	SLS-48	35	TXB24-1 1/2-3	40	TXD18-1/2	38
RE48-1 1/2	36	SLS-54	35	TXB24-1-3	40	TXD18-1/2-3	38
RE48-1 1/2-3	36	SLS-60	35	TXB24-1/2	40	TXD18-1/3	38
RE48-1-3	36	SR-12	33	TXB24-1/2-3	40	TXD18-1/3-3	38
RE48-2	36	SR-16	33	TXB24-2	40	TXD18-1/4	38
RE48-2-3	36	SR-18	33	TXB24-2-3	40	TXD18-1/4-3	38
RE48-3-3	36	SR-20	33	TXB24-3-3	40	TXD24-1	38
RE48-3/4	36	SR-24	33	TXB24-3/4	40	TXD24-1-3	38
RE48-3/4-3	36	SW-1	16	TXB24-3/4-3	40	TXD24-1/2	38
RE48-5-3	36	SW-1 1/2	16	TXB27-1	40	TXD24-1/2-3	38
RE54-1	36	SW-1 1/2-3	16	TXB27-1 1/2	40	TXD24-1/3	38
RE54-1 1/2	36	SW-1-3	16	TXB27-1 1/2-3	40	TXD24-1/3-3	38
RE54-1 1/2-3	36	SW-1/2	16	TXB27-1-3	40	TXD24-1/4	38
RE54-1-3	36	SW-1/2-3	16	TXB27-2	40	TXD24-1/4-3	38
RE54-2	36	SW-1/4	16	TXB27-2-3	40	TXD24-2	38
RE54-2-3	36	SW-1/4-3	16	TXB27-3/4	40	TXD24-2-3	38
RE54-3-3	36	SW-2-3	16	TXB27-3/4-3	40	TXD24-3-3	38
RE54-5-3	36	SW-3-3	16	TXB30-1	40	TXD24-3/4	38
RE60-1	36	SW-5-3	16	TXB30-1 1/2	40	TXD24-3/4-3	38
RE60-1 1/2	36	SW-7 1/2-3	16	TXB30-1 1/2-3	40	TXD27-1	38
RE60-1 1/2-3	36	TL-RB-18	44	TXB30-1-3	40	TXD27-1-3	38
RE60-1-3	36	TXB12-1/2	40	TXB30-1/2	40	TXD27-1/2	38
RE60-2	36	TXB12-1/2-3	40	TXB30-1/2-3	40	TXD27-1/2-3	38
RE60-2-3	36	TXB12-1/3	40	TXB30-2	40	TXD27-2	38
RE60-3-3	36	TXB12-1/3-3	40	TXB30-2-3	40	TXD27-2-3	38
RE60-5-3	36	TXB12-1/4	40	TXB30-3-3	40	TXD30-1/2	38
RE60-7 1/2-3	36	TXB12-1/4-3	40	TXB30-5-3	40	TXD30-1/2-3	38
SBX 30-D	12	TXB12-3/4	40	TXB34-1 1/2	40	TXD30-2	38
SBX 36-B	12	TXB12-3/4-3	40	TXB34-1 1/2-3	40	TXD30-2-3	38
SB 36-B-3	12	TXB15-1/2	40	TXB34-2	40	TXD30-3-3	38
SB 36-B-HL	12	TXB15-1/2-3	40	TXB34-2-3	40	TXD30-3/4	38
SBX 36-D	12	TXB15-1/3	40	TXB34-3-3	40	TXD30-3/4-3	38
SBX 42-B	12	TXB15-1/3-3	40	TXB34-5-3	40	TXD34-1 1/2	38
SB 42-B-3	12	TXB15-1/4	40	TXB42-1 1/2	40	TXD34-1 1/2-3	38
SB 42-B-HL	12	TXB15-1/4-3	40	TXB42-1 1/2-3	40	TXD34-2	38
SBX 42-D	12	TXB15-3/4	40	TXB42-2	40	TXD34-2-3	38
SBX 48-B	12	TXB15-3/4-3	40	TXB42-2-3	40	TXD34-3-3	38
SB 48-B-3	12	TXB18-1	40	TXB42-3-3	40	TXD34-5-3	38
SB 48-B-HL	12	TXB18-1 1/2	40	TXB42-5-3	40	TXD36-2	38
SF-12	33	TXB18-1 1/2-3	40	TXB48-5-3	40	TXD36-2-3	38
SF-16	33	TXB18-1-3	40	TXB48-7 1/2-3	40	TXD36-3-3	38
SF-18	33	TXB18-1/2	40	TXD12-1/2	38	TXD42-1-3	38
SF-20	33	TXB18-1/2-3	40	TXD12-1/2-3	38	TXD42-2	38
SF-24	33	TXB18-1/3	40	TXD12-1/4	38	TXD42-2-3	38
SLS-18	35	TXB18-1/3-3	40	TXD12-1/4-3	38	TXD42-3-3	38
SLS-24	35	TXB18-1/4	40	TXD12-3/4	38	TXD42-5-3	38

# Product Index Listing

MODEL	PAGE	MODEL	PAGE	MODEL	PAGE	MODEL	PAGE
TXD48-3-3	38	UEB48-1 1/2-3	37	UED42-2-3	36		
TXD48-5-3	38	UEB48-1-3	37	UED42-5-3	36		
TXG-12	38	UEB48-2	37	UED48-10-3	36		
TXG-15	38	UEB48-2-3	37	UED48-3-3	36		
TXG-18	38	UEB48-3-3	37	UED48-5-3	36		
TXG-24	38	UEB48-3/4	37	UED48-7 1/2-3	36		
TXG-27	38	UEB48-3/4-3	37	UED60-5-3	36		
TXG-30	38	UEB54-1	37	UED60-7 1/2-3	36		
TXG-34	38	UEB54-1 1/2	37	UHP 24-P	4		
TXG-36	38	UEB54-1 1/2-3	37	UHP 24-PJR	4		
TXG-42	38	UEB54-1-3	37	UHP 24-W	4		
TXG-48	38	UEB54-2	37	UHP 24-WJR	4		
U-12-TE	37	UEB54-2-3	37	UHP 30-IJR	4		
U-18-TE	19	UEB54-3-3	37	UHP 30-P	4		
U-18-TE-HD	19	UEB54-5-3	37	UHP 30-PJR	4		
U-24-TE	19	UEB60-1 1/2	37	UHP 30-W	4		
U-24-TE-HD	19	UEB60-1 1/2-3	37	UHP 30-WJR	4		
U-24-TE-HV	19	UEB60-2	37	WACM-P	6		
UEB24-1/2	37	UEB60-2-3	37	WACM-W	6		
UEB24-1/2-3	37	UEB60-3-3	37	WH-12	34		
UEB24-1/3	37	UEB60-5-3	37	WH-16	34		
UEB24-1/3-3	37	UED18-1	36	WH-18	34		
UEB24-3/4	37	UED18-1-3	36	WH-20	34		
UEB24-3/4-3	37	UED18-1/2	36	WH-24	34		
UEB30-1	37	UED18-1/2-3	36	WH-30	34		
UEB30-1-3	37	UED18-1/3	36	WH-36	34		
UEB30-1/2	37	UED18-1/3-3	36	WH-42	34		
UEB30-1/2-3	37	UED18-1/4	36	WH-48	34		
UEB30-3/4	37	UED18-1/4-3	36	WH-60	34		
UEB30-3/4-3	37	UED24-1	36				
UEB36-1	37	UED24-1-3	36				
UEB36-1 1/2	37	UED24-1/4	36				
UEB36-1 1/2-3	37	UED24-1/4-3	36				
UEB36-1-3	37	UED24-3-3	36				
UEB36-1/2	37	UED24-3/4	36				
UEB36-1/2-3	37	UED24-3/4-3	36				
UEB36-3/4	37	UED30-1 1/2	36				
UEB36-3/4-3	37	UED30-1 1/2-3	36				
UEB42-1	37	UED30-1-3	36				
UEB42-1 1/2	37	UED30-2	36				
UEB42-1 1/2-3	37	UED30-2-3	36				
UEB42-1-3	37	UED30-3-3	36				
UEB42-2	37	UED30-3/4	36				
UEB42-2-3	37	UED30-3/4-3	36				
UEB42-3-3	37	UED36-2	36				
UEB42-3/4	37	UED36-2-3	36				
UEB42-3/4-3	37	UED36-3-3	36				
UEB48-1	37	UED36-5-3	36				
UEB48-1 1/2	37	UED42-2	36				